

TOYOLIFT

Lifting & Material Handling Solutions



ISO 9001:2015 Certified Company

MANUAL CHAIN HOIST Palan A Chaine Manuel

Characteristics

- Capacity ranges from 0.5T to 50T
- Automatic double pawl braking system.
- Double break cover protection.
- Light weight robust construction.
- Low effort to lift maximum load.
- Extra thick asbestos free friction discs.
- Fully forged hooks are fitted with safety latches as standard.
- Galvanized hand chain as standard.
- The hoist is fitted with high grade 80 alloy load chain (black and galvanized with T8 mark).
- Complies with EC Council Directive 2006/42/EC BS EN 13157 and in accordance with ASME B30.16 requirements.

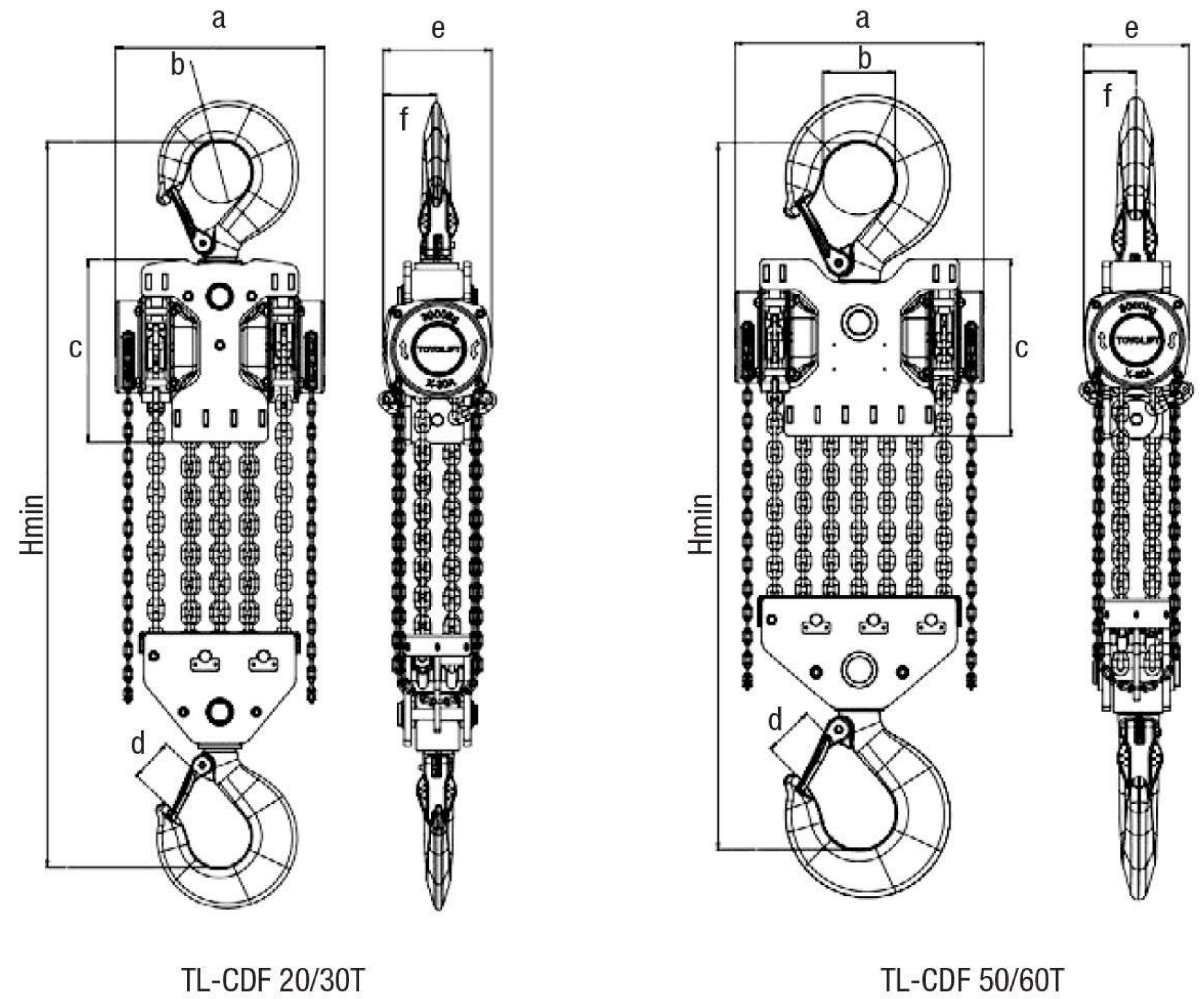
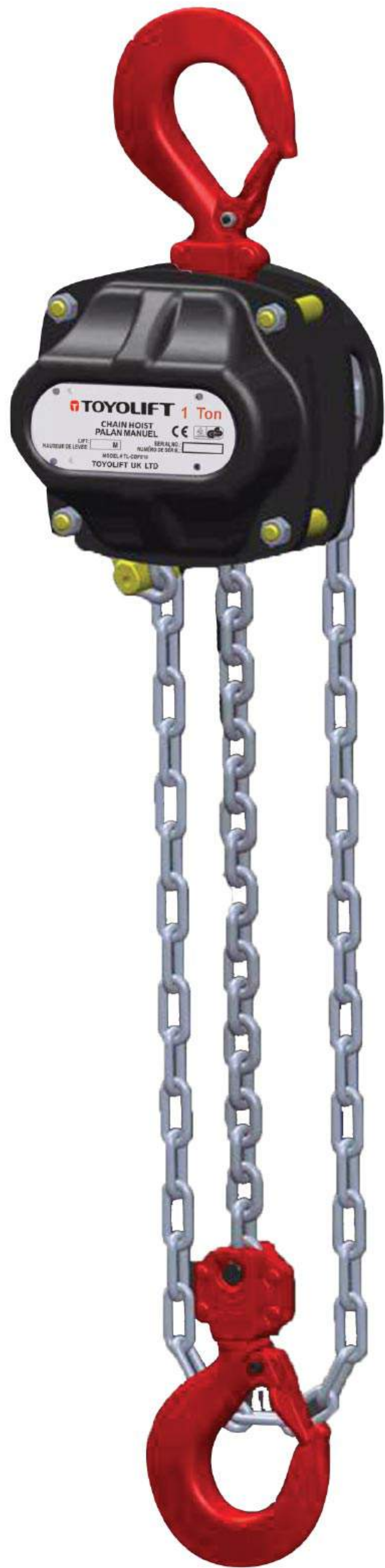
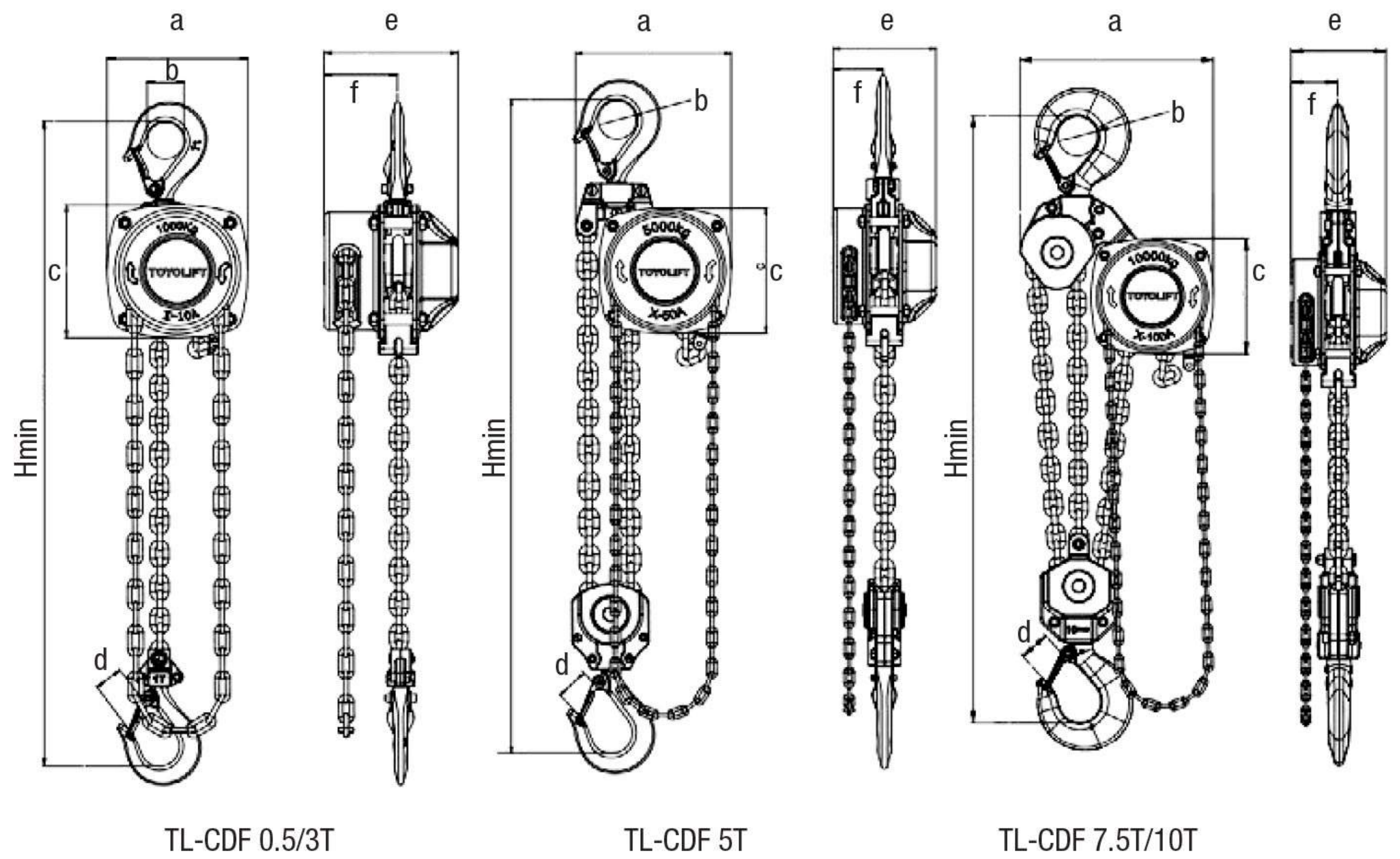

CHAIN HOIST (MODEL: TL-CDF)												
Model	TL-CDF	TL-CDF050	TL-CDF10	TL-CDF15	TL-CDF20	TL-CDF30	TL-CDF50	TL-CDF75	TL-CDF100	TL-CDF150	TL-CDF200	TL-CDF300
Safe Working Load	kg	500	1000	1500	2000	3000	5000	7500	10000	15000	20000	30000
Standard Length	m	3	3	3	3	3	3	3	3	3	3	3
Load chain number of falls		1	1	1	1	1	2	3	3	6	8	12
Effort required to lift max load	N	240	305	340	360	370	370	80	80	360	380	400
Load Chain size	mm	5x15	6x18	8x24	8x24	10x30	10x30	10x30	10x30	10x30	10x30	10x30
Running test load	kg	750	1500	2250	3000	4500	7500	15000	15000	22500	30000	45000
Net weight	kg	5.7	11	17	17	26	40	73	73	160	176	258
Packaging Dimensions	cm	27.5x14.5x15.5	28x17x18.5	31x17.5x22	31x17.5x22	39x19x26	44x24x26	58x46.5x24.5	58x46.5x24.5			
Extra Weight/ meter of lifting	kg/m	0.9	0.9	0.9	0.9	0.9	0.9	0.9	0.9	1.8	1.8	1.8
Dimensions (mm)	a	122	152	176	176	216	216	343	343	441	429	533
	b	35	44	46	49	60	68	91	91	120	125	150
	c	118	145	170	170	204	204	204	204	400	376	373
	d	22	30	32	34	41	47	58	58	78	105	105
	e	119	145	157	157	167	167	167	167	222	222	220
	f	65	79	81	81	83	83	83	83	110	113	109
	Hmin		311	361	413	413	431	660	705	705	1094	1100

*Remarks : Hoists with the lift in other length are also available

MANUAL LEVER HOIST

Palan A Levier Manuel

Characteristics

- TOYOLIFT lever hoist is universal, manual hoist for tensioning and lashing in any direction.
- The ratchet lever hoist features compact design and robust, deep drawn, stamped steel construction.
- High quality materials ensure light weight without infringing reliability.
- Asbestos free brake, holding load at any desired height.
- Top & Bottom hooks are fitted with safety latches as standard.
- The load chain can be pulled freely and easily through the hoist in both directions to attach the load or to tension the chain.
- Short hand lever with rubber grip.
- Hand lever operates with little effort due to optimal gear ratio.
- Drop forged steel suspension & load hooks are heat treated.
- The hoist is fitted with high grade 80 alloy load chain (black and galvanized with T8 mark)
- Complies with EC Council Directive 2006/42/EC, BS EN 13157 and in accordance with ASME B30.21 requirements.

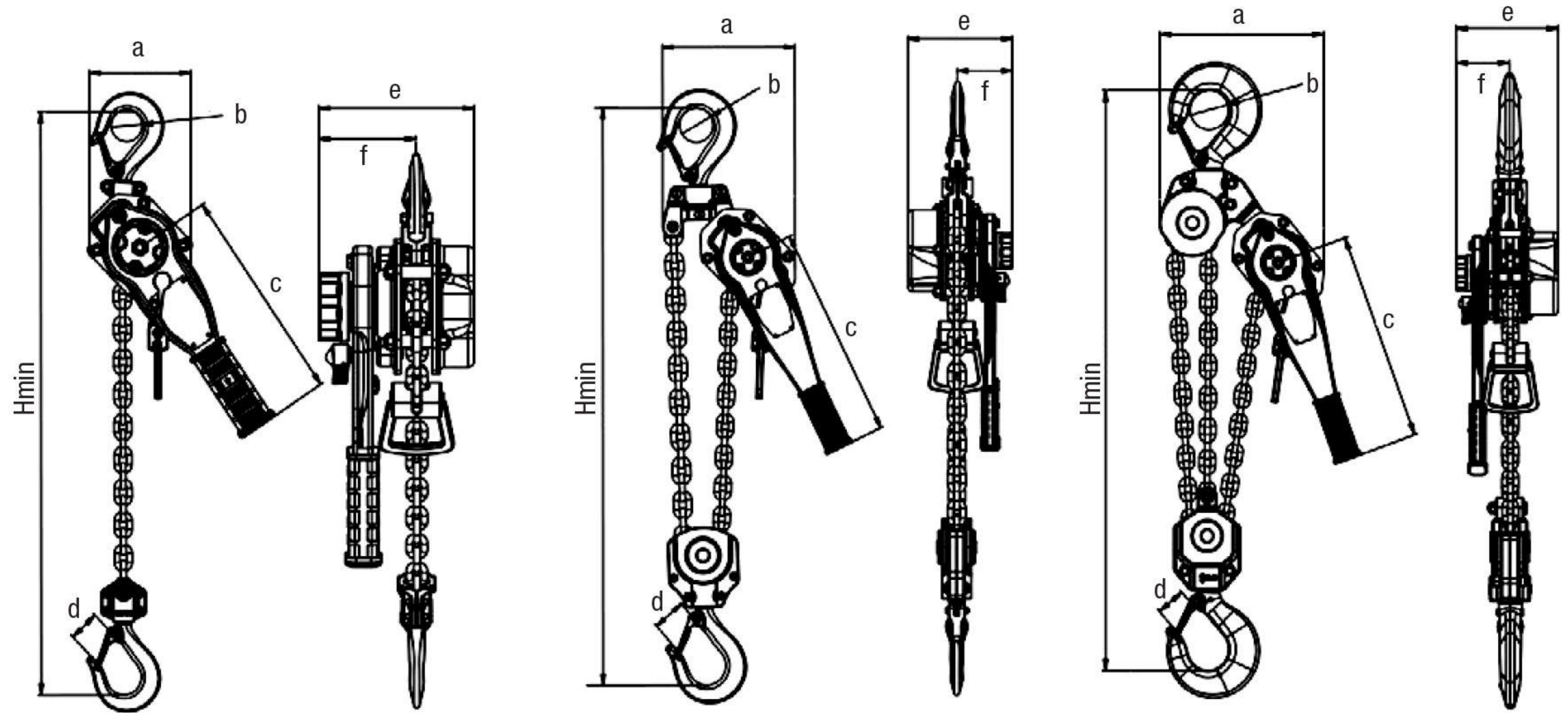

TL-LDH 0.75/3T

TL-LDH 6T

TL-LDH 9T



LEVER HOIST [Model:TL-LDH]						
MODEL	TL-LDH	TL-LDH075	TL-LDH150	TL-LDH300	TL-LDH600	TL-LDH900
Safe Working Load	kg	750	1500	3000	6000	9000
Standard Length	m	1.5	1.5	1.5	1.5	1.5
Load chain number of falls		1	1	1	2	3
Effort required to lift max load	N	220	240	330	360	380
Running test load	kg	1125	2250	4500	9000	13500
Load chain Size	mm	6x18	7.1x21	9x27	9x27	9x27
Net weight	kg	5.3	8.6	15.2	23	43
Gross weight	kg	5.6	8.9	15.6	23.5	44.5
Packing Dimensions	cm	31.5x16x12	35x18x13	48x20x13.5	48x21.5x17	53x28x25
Extra Weight/ meter of lifting	kg/m	0.7	1.1	1.8	3.6	5.4
Dimensions (mm)	a	115	137	169	238	300
	b	39	44	60	68	91
	c	239	259	374	374	374
	d	28	32	41	47	61
	e	146	162	187	187	187
	f	91	95	98	98	98
	Hmin		320	360	431	500

*Remarks : Hoists with the lift in other length are also available

All dimensions are subject to change without prior notice

ELECTRIC CHAIN HOIST (TL-SSDHL - Model) Palan électrique à chaîne



Wireless Remote Control for Electric Hoist also available

TECHNICAL PARAMETERS

Capacity (Ton)	Hoist lifting motor (Up & Down)				Hoist Weight (Kg)
	Lifting speed (M/Min)	Power (Kw)	Dia. of Chain	No. of Chain falls	
0.5	7.2	0.8	Ø6.3	1	53
1	6.6	1.5	Ø7.1	1	67
2	6.6	3.0	Ø10.0	1	120
3	4.4	3.0	Ø10.0	2	137
5	2.7	3.0	Ø11.2	2	148
7.5	1.8	3.0	Ø11.2	3	203
10	2.7	3.0x2	Ø11.2	4	344
15	1.8	3.0x2	Ø11.2	6	412
20	1.4	3.0x2	Ø11.2	8	522
25	1.1	3.0x2	Ø11.2	10	560

* Power supply - 380V/415V, 3PH, 50/60Hz, 1440RPM.

Standard: BS EN 14492-1 and accordance with ASME requirements

All dimensions are subject to change without prior notice

ELECTRIC CHAIN HOIST WITH TROLLEY (DPC-SSDHL - Model) Palan électrique à chaîne avec chariot

TECHNICAL PARAMETERS

Capacity (Ton)	Power (Kw)	Trolley (Right & Left)		Chain Hoist (Up & Down)			Hoist & Trolley weight (Kg)
		Traveling speed (M/Min)	Beam width (mm)	Lifting speed (M/Min)	No. of Chain falls	Load chain dia. mm	
0.5	0.4	21	50-102	7.2	1	Ø6.3	80
1	0.4	21	58-153	6.6	1	Ø7.1	114
2	0.4	21	82-178	6.6	1	Ø10.0	175
3	0.75	21	100-178	4.4	2	Ø10.0	203
5	0.75	21	100-178	2.7	2	Ø11.2	236
7.5	0.75	21	100-178	1.8	3	Ø11.2	308
10	0.75	21	152-220	2.7	4	Ø11.2	489
15	0.75 x 2	21	152-220	1.8	6	Ø11.2	629
20	0.75 x 2	21	152-220	1.4	8	Ø11.2	777
25	0.75 x 2	21	152-220	1.1	10	Ø11.2	870

* Power supply - 380V/415V, 3PH, 50/60Hz, 1440RPM.

Standard: BS EN 14492-1 and accordance with ASME requirements

All dimensions are subject to change without prior notice

ELECTRIC TROLLEY (DPC-T- Model) Chariot porte palan électrique



TECHNICAL PARAMETERS

Capacity Ton	Power (Kw)	Beam width (mm)	Traveling speed (M/min)	Trolley weight (Kg)
0.5	0.4	50-102	21	30
1	0.4	58-153	21	47
2	0.4	82-178	21	55
3	0.75	100-178	21	66
5	0.75	100-178	21	88
7.5	0.75	100-178	21	105
10	0.75	152-220	21	145
15	0.75 x 2	152-220	21	217
20	0.75 x 2	152-220	21	255
25	0.75 x 2	152-220	21	310

* Power supply - 380V/415V, 3PH, 50/60Hz, 1440RPM.

Standard: BS EN 14492-1 and accordance with ASME requirements

All dimensions are subject to change without prior notice

SNATCH BLOCK

Poulie à palier d'accrochage

WIRE ROPE SNATCH BLOCK WITH SHACKLE [MODEL: TL-SB]							
Model	Capacity (Ton)	Sheave Dia (mm)	A2 (mm)	B (mm)	C (mm)	Wire Rope (mm)	Net Weight (kg)
TL-SB020	2	75	286	82	70	7-9	4
TL-SB040	4	115	345	120	70	10-12	5.68
TL-SB080	8	150	475	160	93	20-22	14.4
TL-SB100	10	245	672	250	110	24-26	37.5
TL-SB120	12	250	679	260	115	24-26	37.5
TL-SB150	15	300	788	310	133	26-28	65
TL-SB220	22	355	952	365	140	28-32	90
TL-SB300	30	400	1126	415	155	32-35	135
TL-SB300	30	500	1256	514	162	32-35	210

- Drop forged, heat treated swivel shackle
 - Safety factor 4:1
 - Shackle (TL-SB type)
- Standard: EN 13157

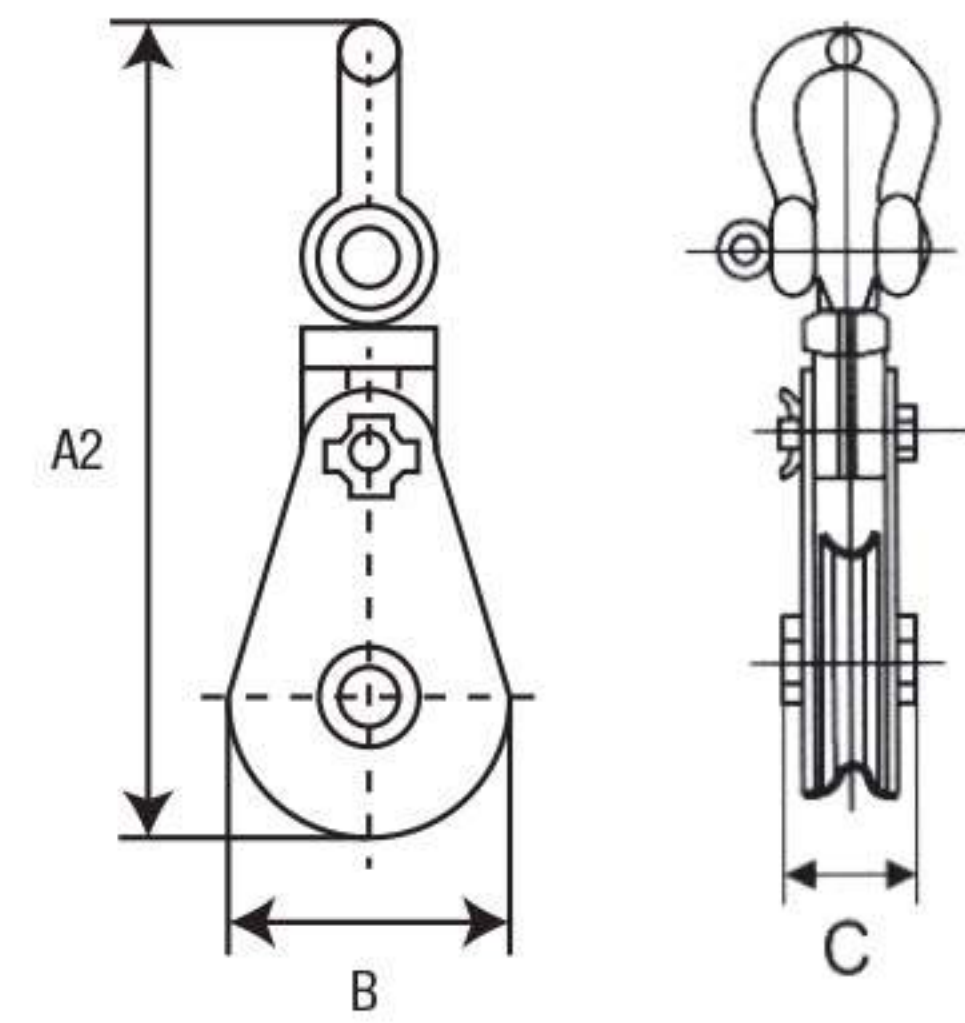

RACK JACK

Vérin de levage manuel

Characteristics

- Top quality steel structure makes high safety and durability.
- Equipped with fixed claw.
- Collapsible handle for easy storage, operation and maintenance.
- Fast lift speed makes it work more efficiently.

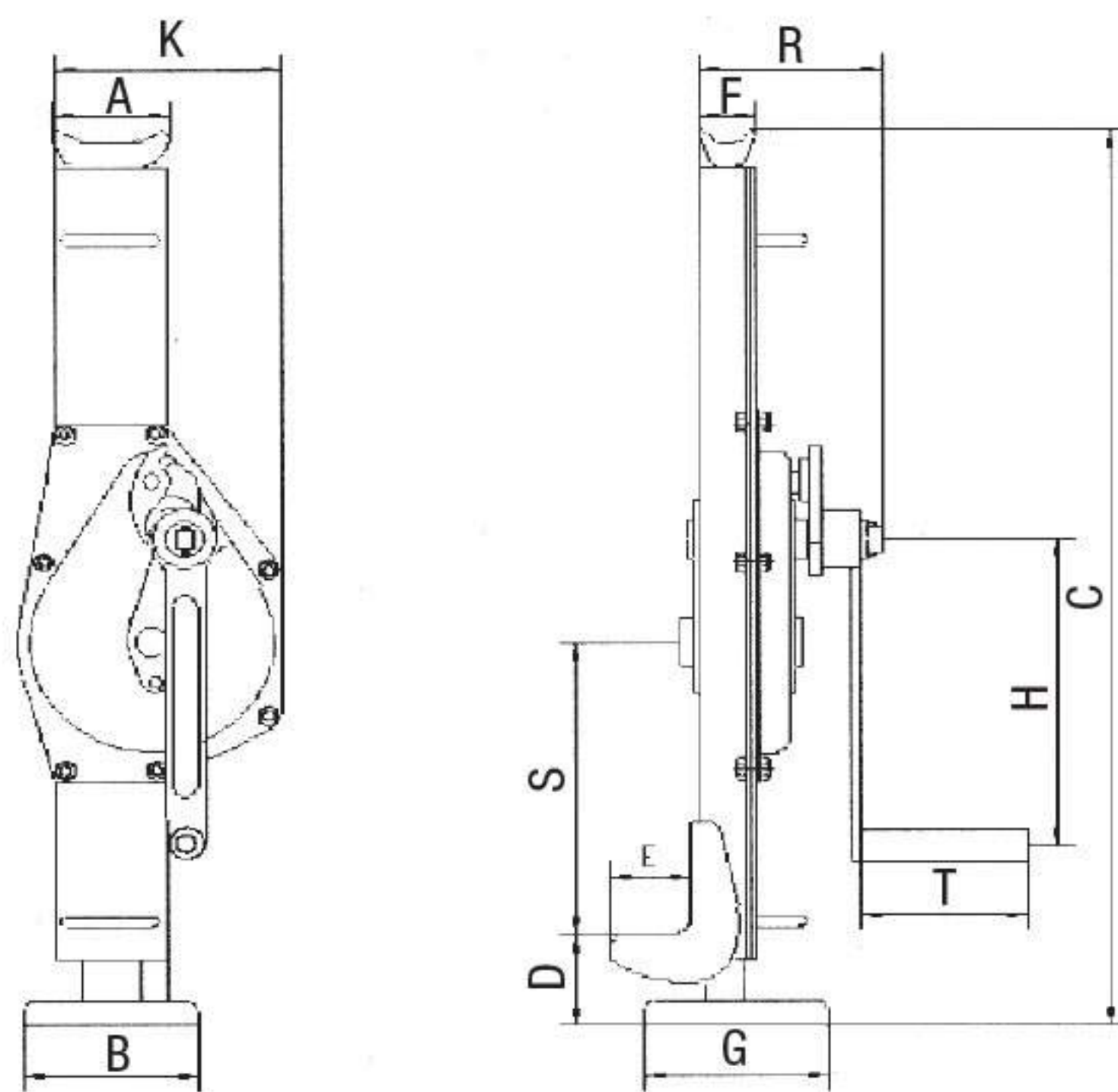
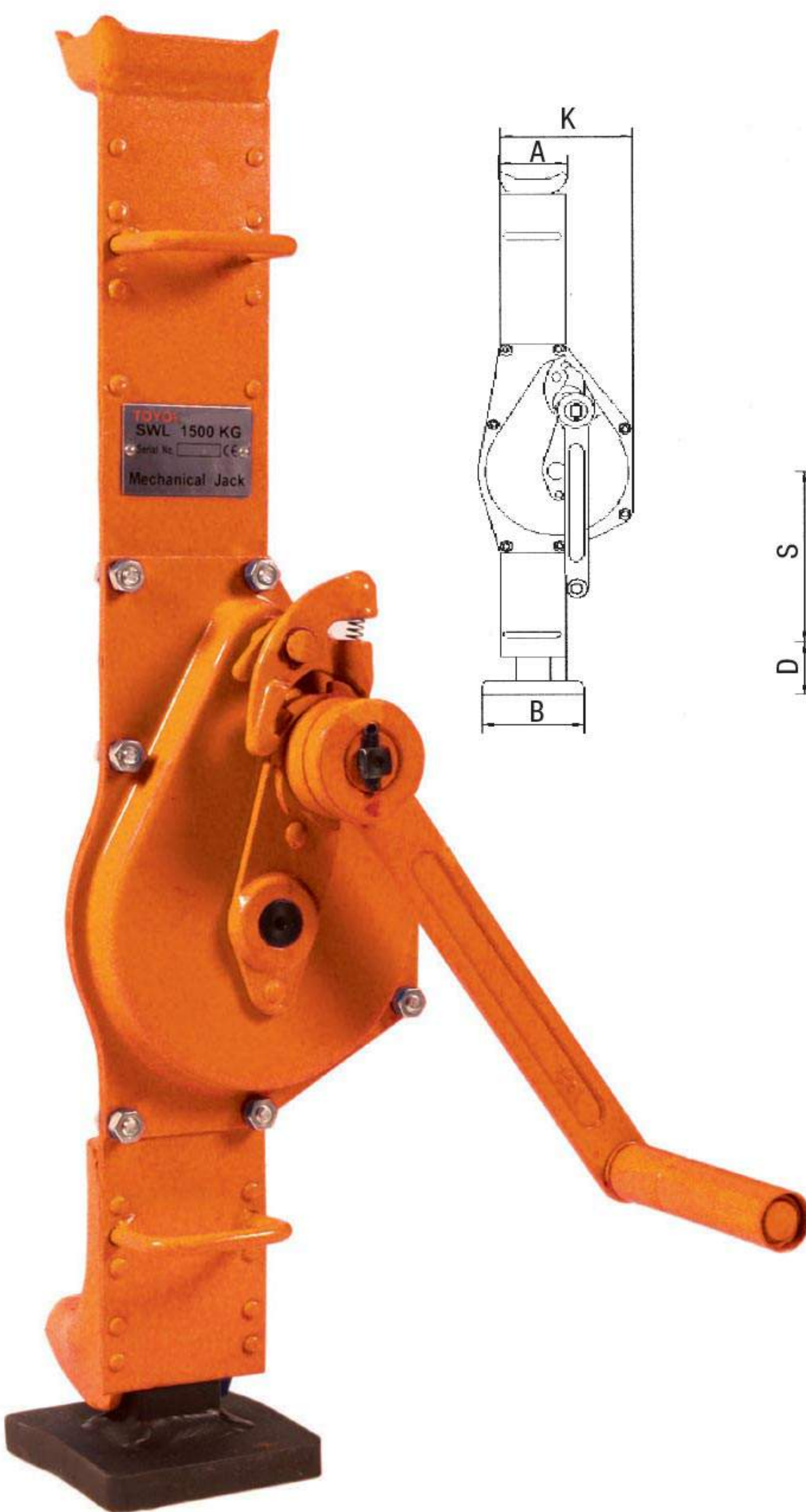

RACK JACK (MODEL: TL-RJ)					
Model	TL-RJ015	TL-RJ030	TL-RJ050	TL-RJ100	
Capacity (Ton)	1.5	3	5	10	
Tested Load (Ton)	2.25	4.5	7.5	15	
Effort required to lift max. load (N)	300	350	400	580	
(Dimensions mm)	A	77	83	105	
	B	100	130	145	
	C	605-905	715-1085	730-1080	795-1160
	D	55-355	60-430	70-420	83-448
	E	55	60	70	80
	F	46	45	68	73
	G	110	135	170	170
	H	225	285	285	330
	K	121	200	190	252
	R	119	140	155	185
S	185	230	220	220	
T	126	126	126	255	
Net weight (Kg)	10.7	21.3	27	47	

Standard: EN 1494:2000

WIRE ROPE GRIP

Serre-câble

Size available from 1/4" to 3" (Galvanized)

Top quality steel structure makes high safety and durability.

Standard: Federal Specification FF-C-450



BEAM CLAMP

Pince d'accrochage de poutre

BEAM CLAMP (MODEL: TL-BC)						
Model		TL-BC010	TL-BC020	TL-BC030	TL-BC050	TL-BC100
Rated Load	(Ton)	1	2	3	5	10
Tested Load	(Ton)	1.5	3	4.5	7.5	15
Flange width	mm	75-220	75-220	80-320	80-320	90-320
(Dimensions mm)	Max. A	260	260	354	354	365
	Min. B	180	180	235	235	320
	Max. B	260	360	490	490	505
	C	64	74	103	110	120
	D	5	6	8	10	12
	E	215	215	260	260	280
	Max. F	155	155	225	225	235
	Min. F	102	102	140	140	170
	Min. G	25	25	45	45	50
H	22	22	24	28	40	
Net weight	Kg	4.5	5	10.5	11	16

Standard: EN 13155

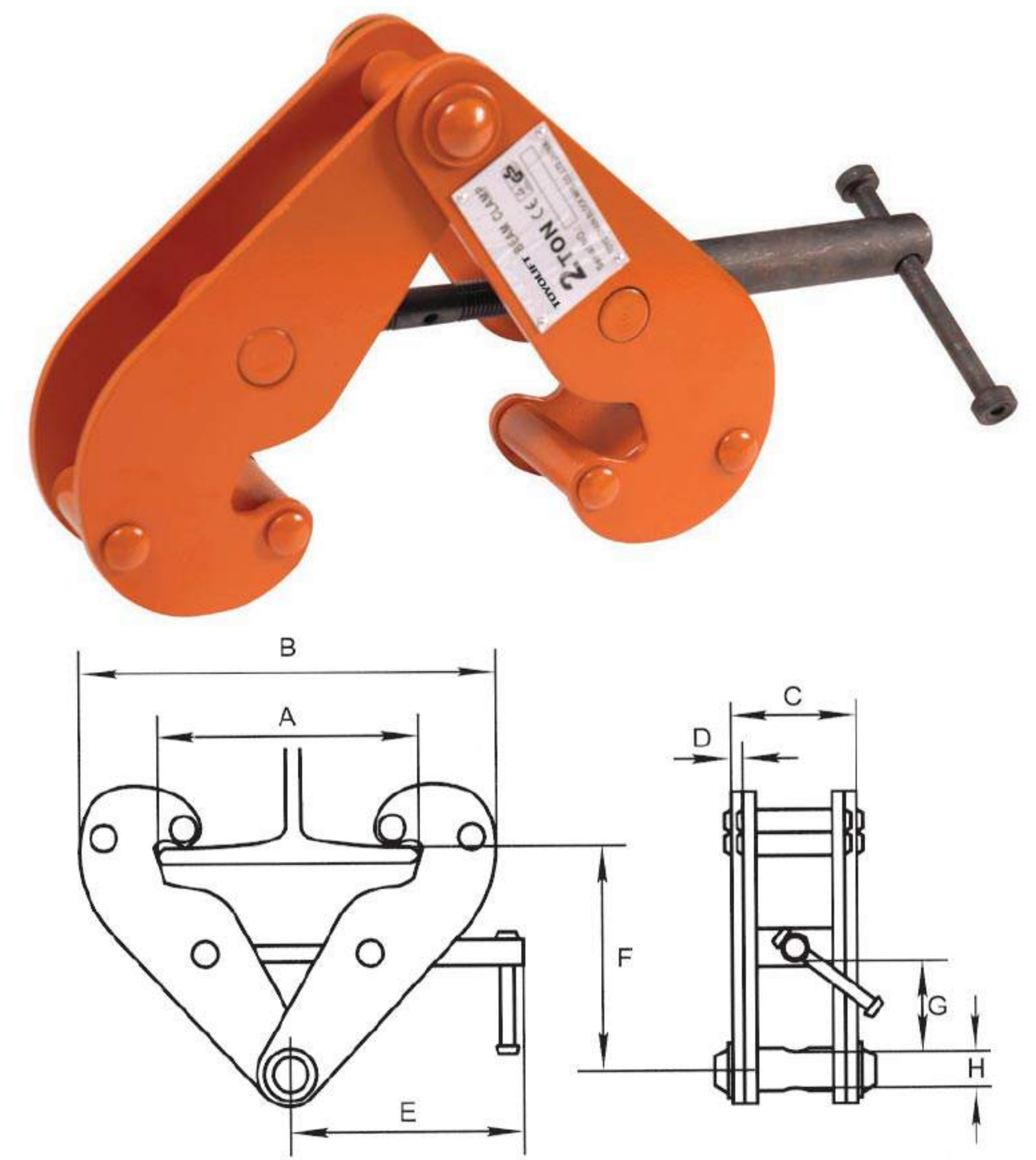

HORIZONTAL PIPE LIFTING CLAMP (Supplied with Shackle)

Pince de levage des pipes

Model	Capacity per pair (Ton)	Jaw opening (R) (mm)	Dimensions (mm)						Weight (Kg)
			A	B	C	D	E	F	
TL-PLC015	1.5	40	125	30	220	70	35	27	2
TL-PLC030	3	40	140	32	228	70	35	27	2.9
TL-PLC040	4	50	145	32	228	70	40	30	4
TL-PLC060	6	50	150	35	232	70	40	30	5
TL-PLC080	8	70	155	35	260	70	40	30	6.7
TL-PLC120	12	70	175	35	322	70	45	33	10
TL-PLC160	16	70	175	35	322	70	55	40	13

Standard: EN 13155

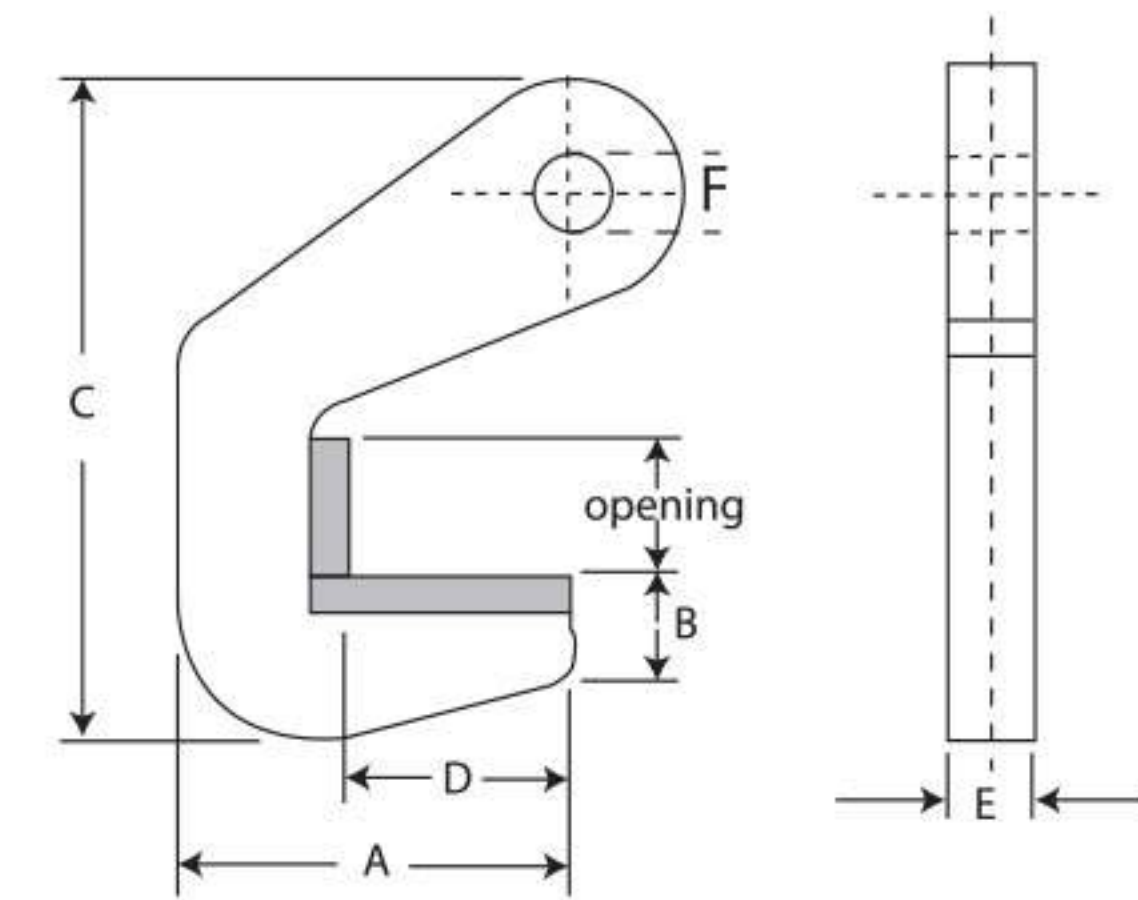

HORIZONTAL PLATE LIFTING CLAMP

Pince de levage de plaques

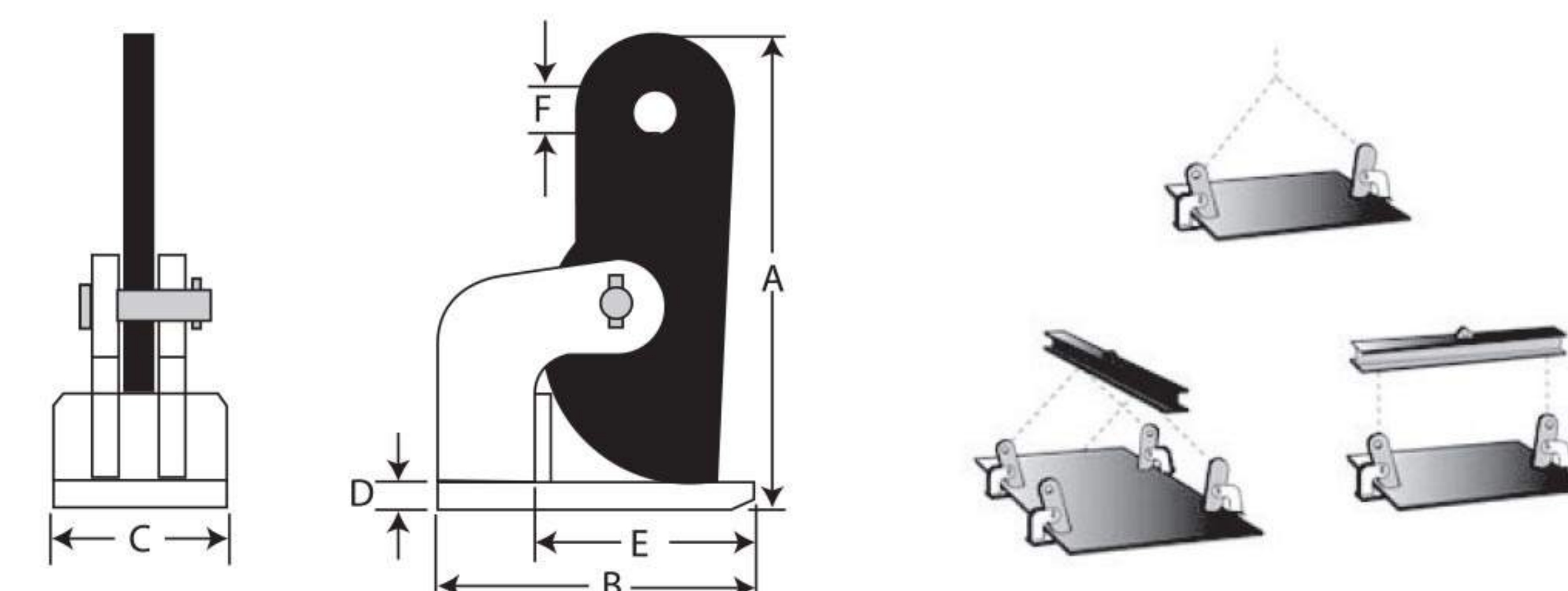
TYPE	Capacity per pair (Ton)	Jaw opening (mm)	Dimensions (mm)						Weight (Kg)
			A	B	C	D	E	F	
TL-FHX010	1	0-60	210	165	80	12	110	25	6
TL-FHX015	1.5	0-60	285	180	80	14	120	25	6.5
TL-FHX020	2	0-60	285	180	80	15	120	25	7.5
TL-FHX030	3	0-60	303	220	90	18	145	30	10
TL-FHX050	5	0-60	309	220	110	25	135	30	15.5
TL-FHX100	10	0-60	330	225	110	25	140	40	23

Standard: EN 13155

PLATE AND BEAM LIFTING CLAMPS

Pince de lavage des poutres et des plaques



VERTICAL LIFTING CLAMP (MODEL: TL-LC)					
Model		TL-LC010	TL-LC020	TL-LC030	TL-LC050
Capacity	(Ton)	1	2	3	5
Tested Load	(Ton)	2	4	6	10
Jaw Opening	(mm)	0-22	0-30	0-40	0-50
Dimensions (mm)	A	25	35	45	55
	B	33	40	50	55
	C	129	155	182	245
	D	50	55	60	68
	E	25	35	37	45
	F	220-260	255-300	305-370	375-435
	G	30	35	44	58
	H	144	170	210	247
	I	54	60	73	77
	J	14	16	18	18
Net weight	Kg	3.6	5.5	10	17

Standard: EN 13155



VERTICAL LIFTING CLAMP (MODEL: TL-VC)				
Model	Capacity	Jaw opening size	Test load	Net weight
	(Ton)	(mm)	(Ton)	(Kg)
TL-VC008	0.8	0-15	1.6	2
TL-VC016	1.6	0-20	3.2	7.6
TL-VC032	3.2	0-25	6.4	16.2
TL-VC080	8	0-45	16	34
TL-VC120	12	50-90	24	50
TL-VC160	16	60-100	32	65

Standard: EN 13155

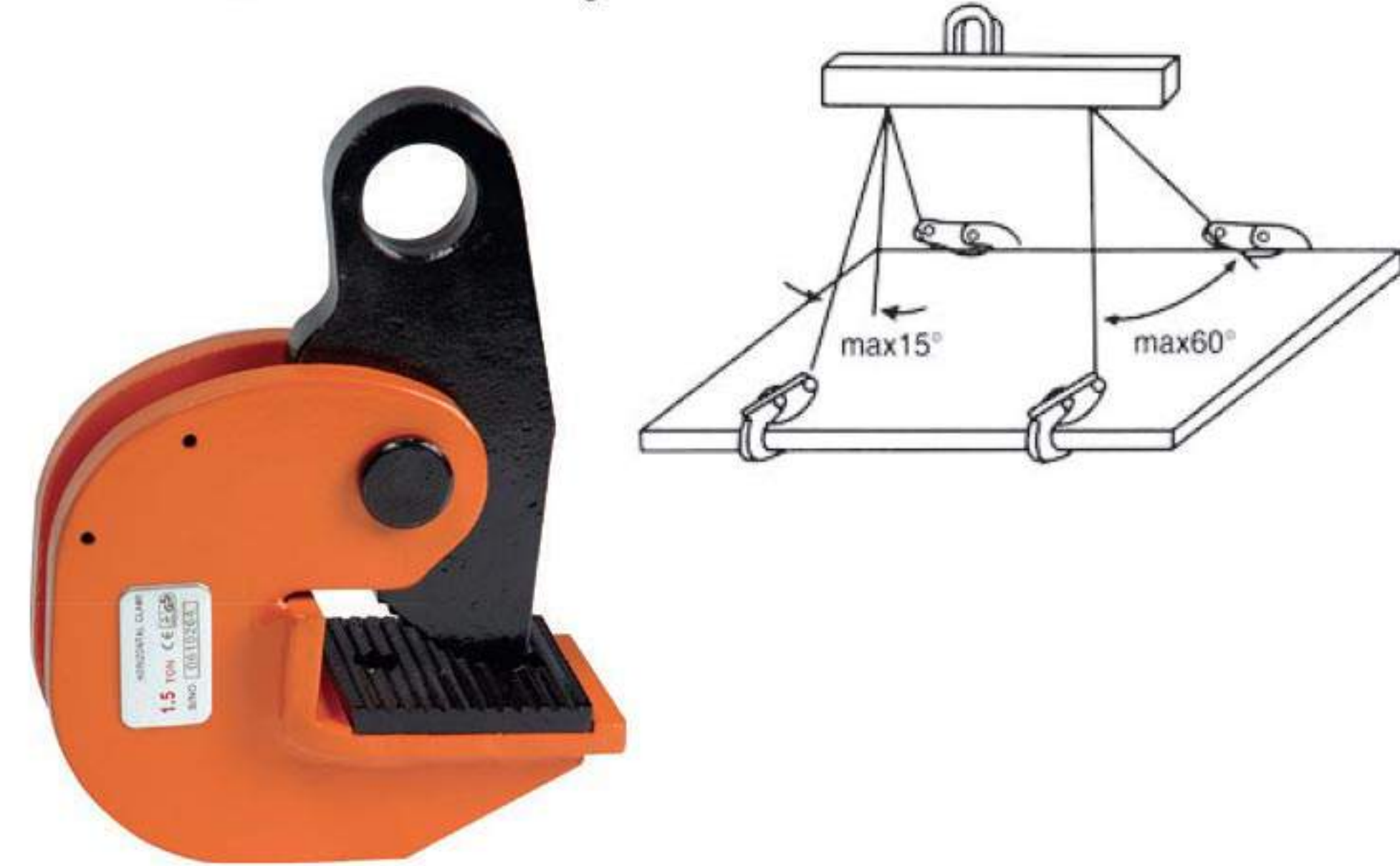
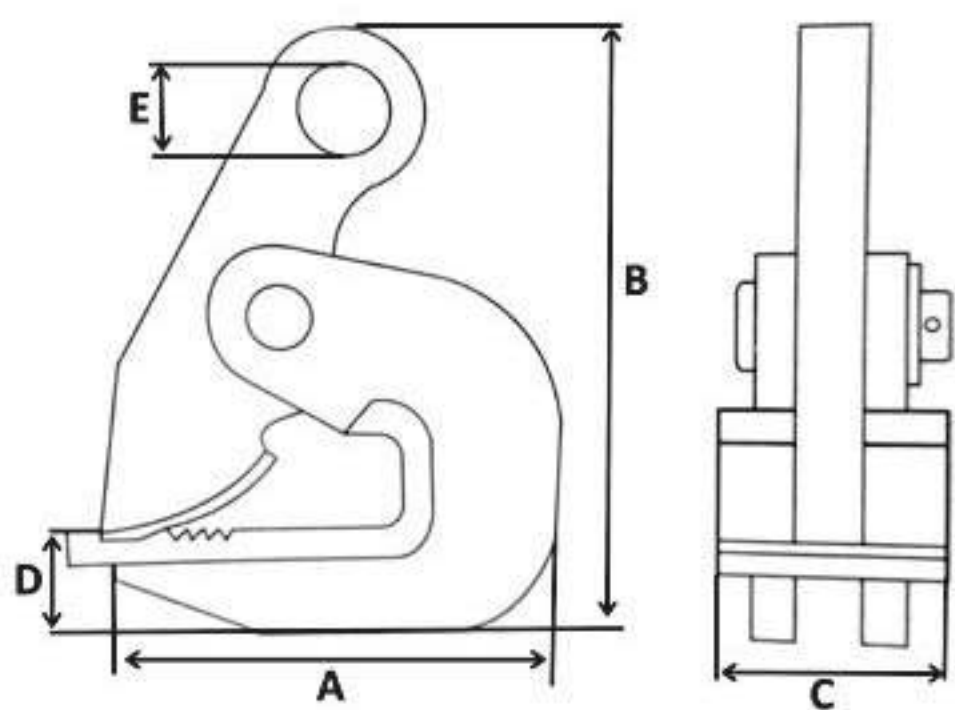

HORIZONTAL LIFTING CLAMP (MODEL: TL-HC)							
Model		TL-HC015	TL-HC020	TL-HC030	TL-HC004	TL-HC060	TL-HC 100
Rated capacity	(Ton /pair)	1.5	2	3	4	6	10
Test load	(Ton /pair)	3	4	6	8	12	20
Jaw Opening	(mm)	0-25	0-30	0-30	0-40	0-45	0-55
Dimensions (mm)	A	126	148	155	172	180	180
	B	165	205	206	245	245	260
	C	50	65	65	68	70	74
	D	42	48	48	58	58	58
	E	22	25	25	30	30	30
Net weight	(Kg/Pair)	5	7	8	10	12	15

Standard: EN 13155

LOAD BINDER

Tendeur de chaîne

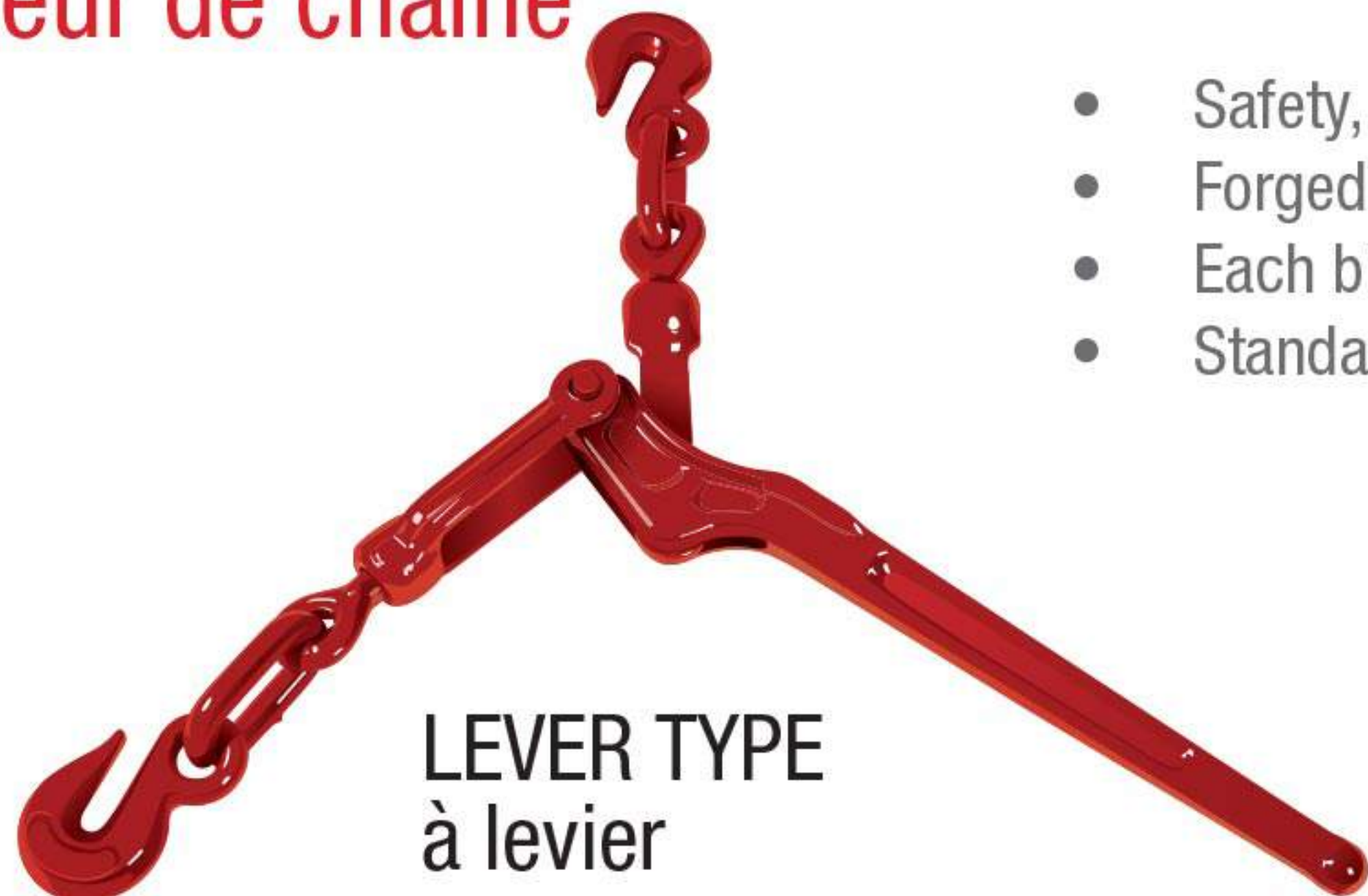

- Safety, design for easy operation.
- Forged and heat treated for extra strength.
- Each binder individually proof tested.
- Standard: EN 12195-3



Min-Max. Chain Size	Inch	1/4-5/16	5/16-3/8	3/8-1/2	1/2-5/8
Working Load Limit	lbs	2600	5400	9200	11000
Proof Load	lbs	5200	10800	18400	22000
Minimum Ultimate Load	lbs	7800	19000	28000	44000
Weight/Each	lbs	3.52	8.37	12.11	19.7
Handle Length	Inch	11.42	15.43	17.24	21.00

Min-Max. Chain Size	Inch	1/4-5/16	5/16-3/8	3/8-1/2	1/2-5/8
Working Load Limit	lbs	2600	5400	9200	13000
Proof Load	lbs	5200	10800	18400	26000
Minimum Ultimate Load	lbs	9200	19000	33000	46000
Weight/Each	lbs	3.52	10.50	12.90	14.38
Handle Length	Inch	7.16	13.42	13.92	13.92

All dimensions are subject to change without prior notice

HAND PALLET TRUCK Transpalette Manuelle

Hand
Pallet Truck
with Digital Scale
available

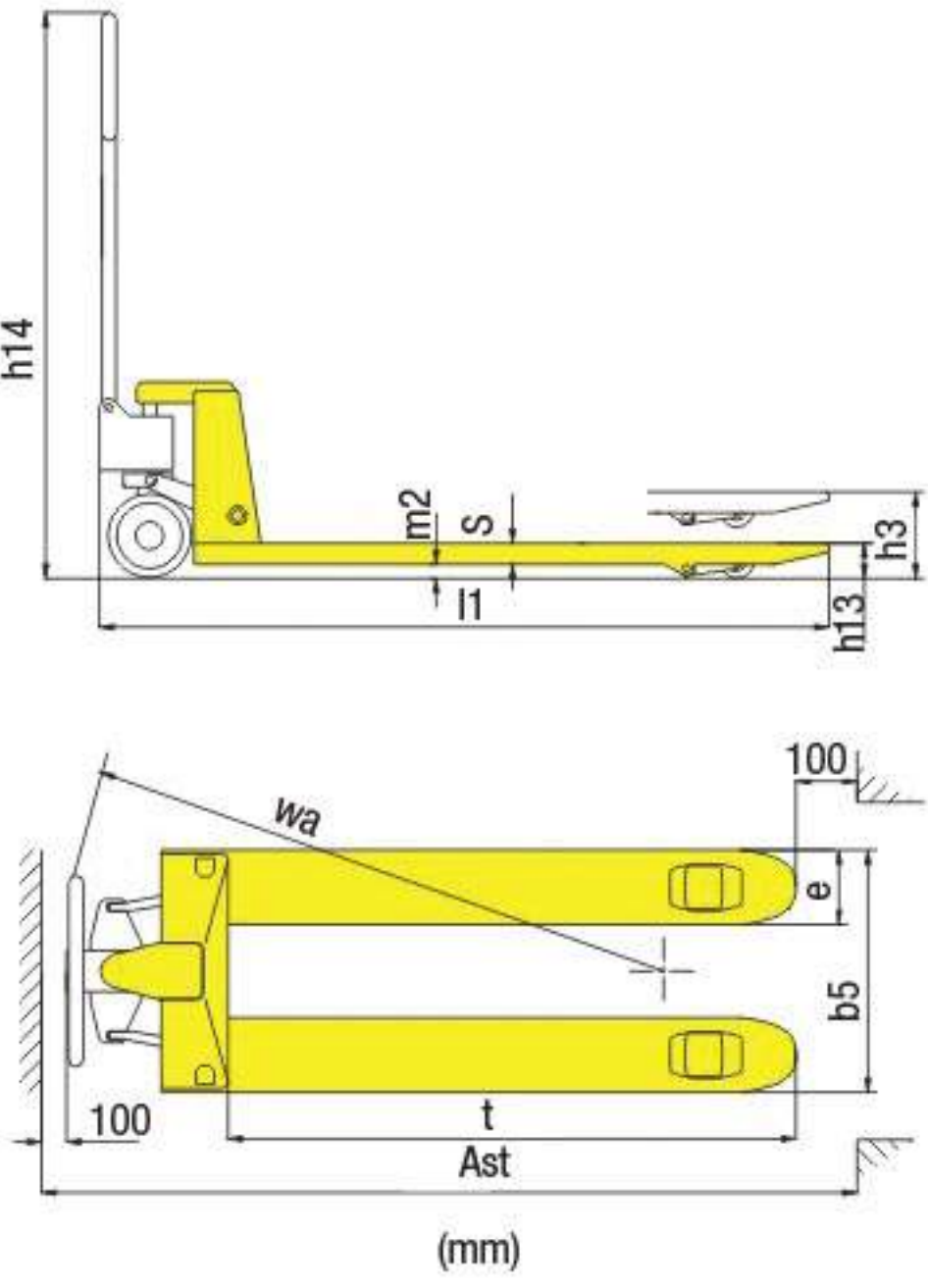

Model		TL-BF25	TL-BF35	TL-WB50
Capacity	Ton	2.5	3.5	5
Service weight	kg	70	90	105
Steering wheel	mm	ø200	ø180	ø200
Fork wheel	mm	ø80	ø75	ø84
Max. lift height	h3(mm)	185	175	195
Total height	h14(mm)	1224	1214	1240
Lowered fork height	h13(mm)	85	75	88
Overall length	l1(mm)	1533/1603	1533/1603	1533/1603
Fork dimension	s/e/t	50/160/1150	50/160/1150	60/160/1150
Distance between fork-arms outside	b5(mm)	550	550	550
Ground clearance centre of wheel base	m2(mm)	16	16	16
Aisle width for pallets 1000x1200 crossways	Ast(mm)	1730/1800	1730/1800	1730/1800
Aisle width for pallets 800x1200 lengthways	Ast(mm)	1730/1800	1730/1800	1730/1800
Turning radius	Wa(mm)	1266/1336	1266/1336	1266/1336

Standard: EN ISO 3691-5: 2014



Adjustable pump cap



Adjustable straight tappet



Option; fully rubber wrapped handle



Entry roller for easy operation

WIRE ROPE WINCH Tirfor à câble

**NEW
5.4 TON**

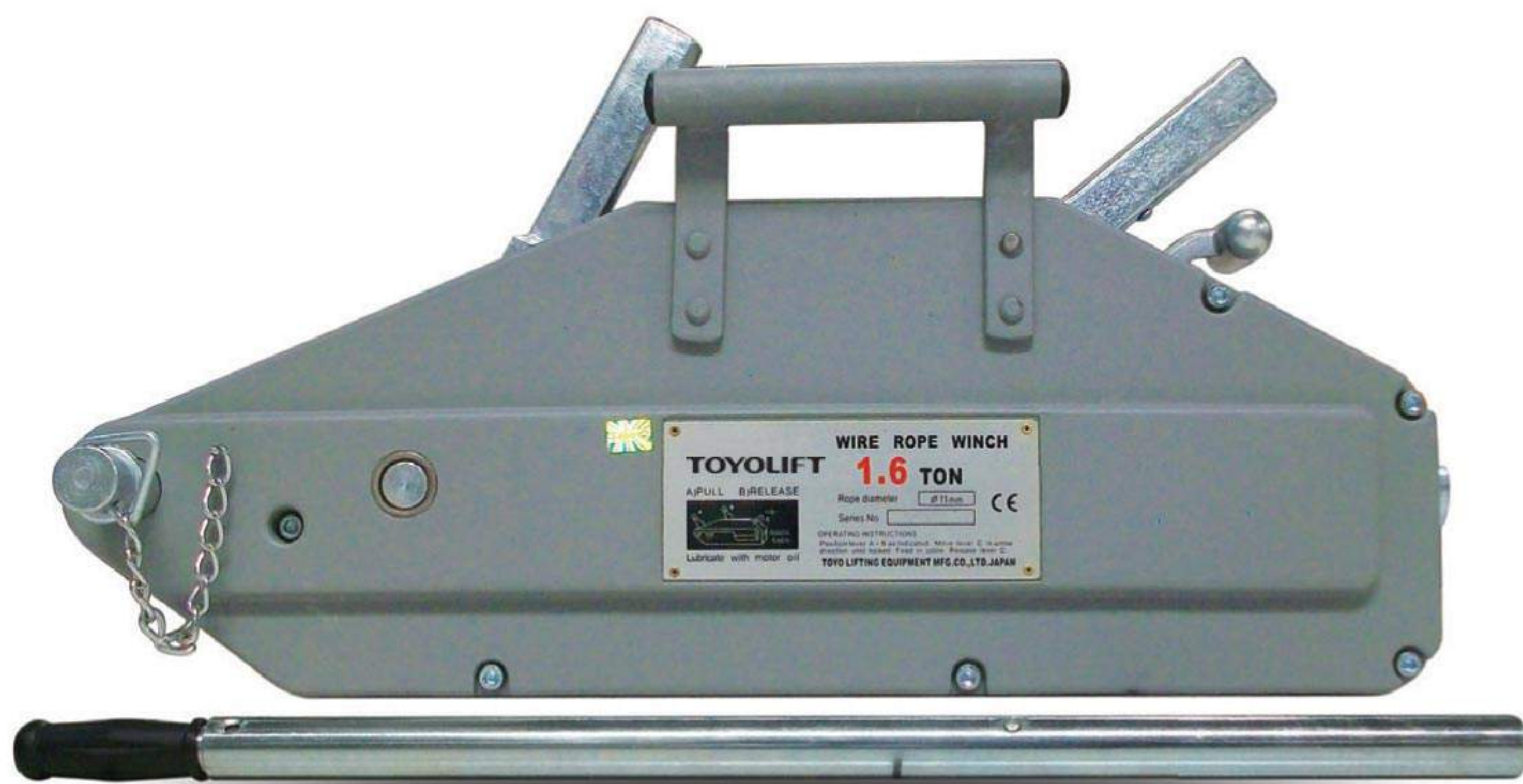

WIRE ROPE WINCH (ALUMINIUM BODY) [MODEL: TL-WP]

MODEL		TL-WP008	TL-WP016	TL-WP032	TL-WP054
Rated lifting capacity	Ton	0.8	1.6	3.2	5.4
Rated pulling capacity	Ton	1.2	2.4	4.8	8.1
Rated advance per full stroke	mm	52	55	28	25
Lever pull at SWL	Kg	34.77	40.78	44.66	86.67
Rope diameter	mm	8.3	11	16	20
Standard length of wire rope	m	20	20	20	20
Net weight without cable	Kg	6.7	12.3	22.2	56.5
Dimensions (mm)	A	426	545	660	930
	B	238	270	325	480
	C	64	78	100	152
	L1	-	692	692	680
	L2	-	1200	1200	1120
	L3	800	-	--	-

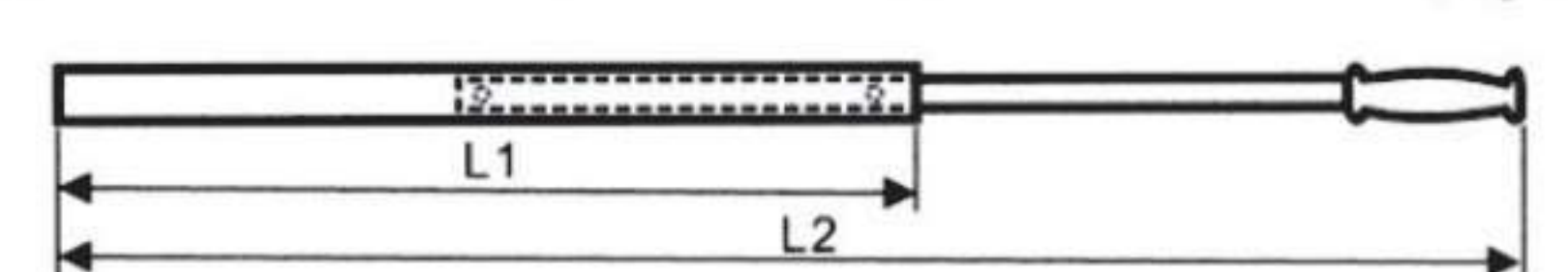
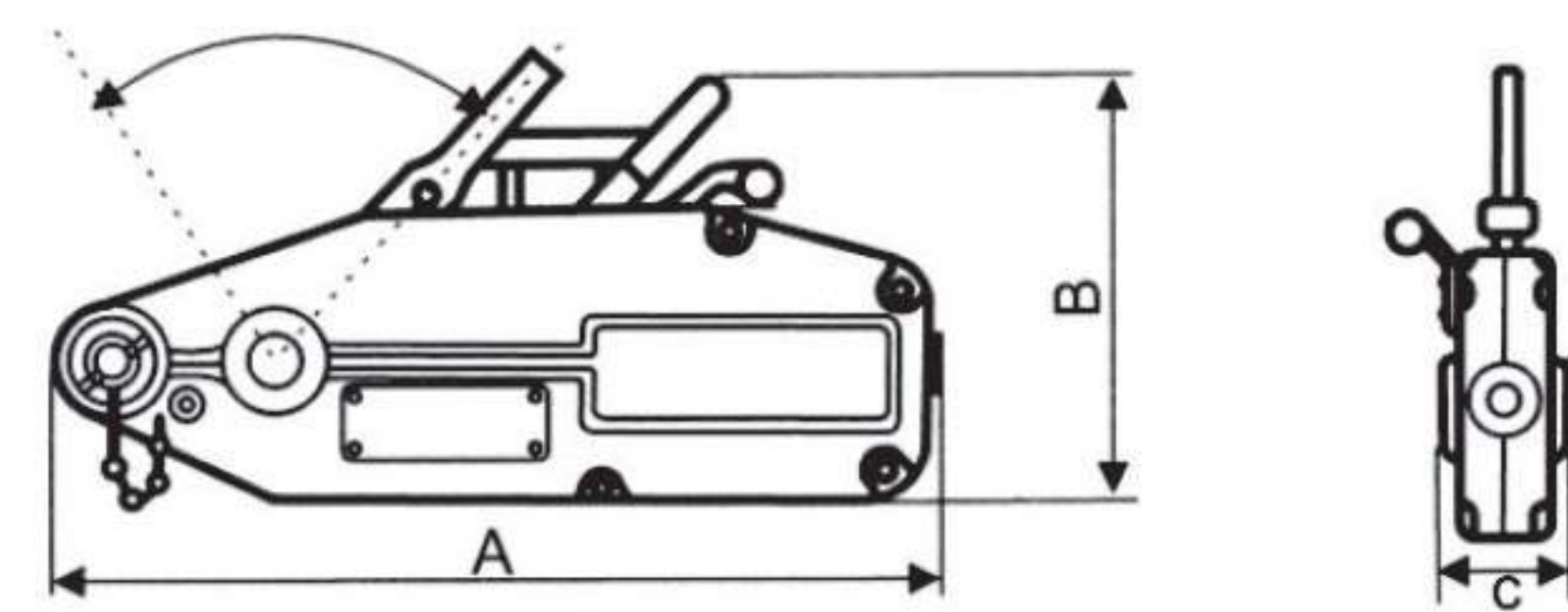

1600KGS, 3200KGS, 5400KGS

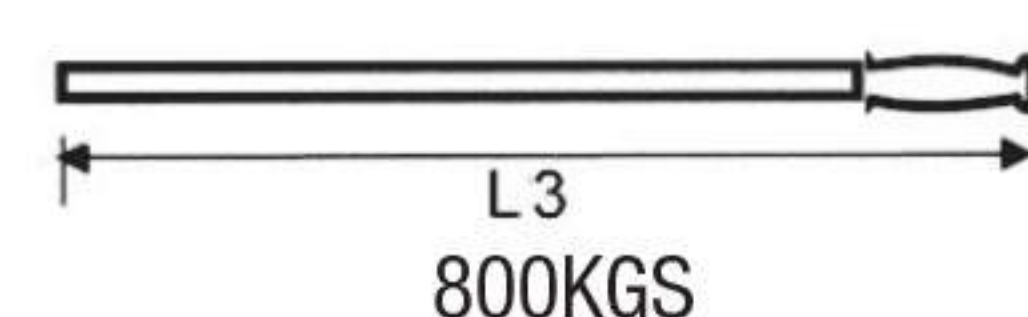

800KGS

Standard: EN 13157

All dimensions are subject to change without prior notice

ALLOY SHACKLES Manilles D' Alliage

SCREW PIN BOW SHACKLES TL-209

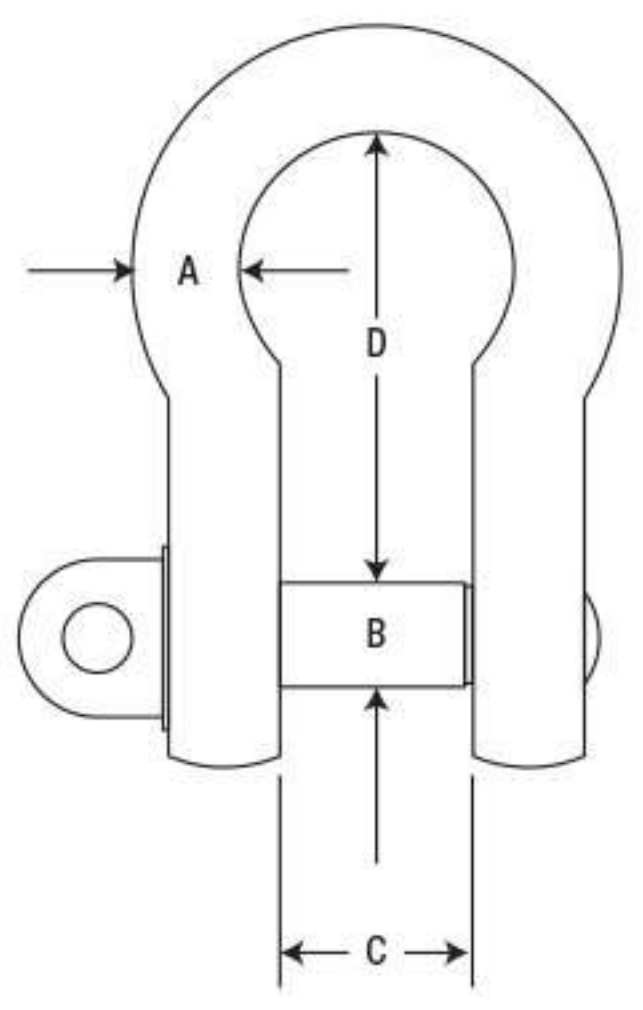

Screw Pin Bow Shackle



SCREW PIN DEE SHACKLES TL-210

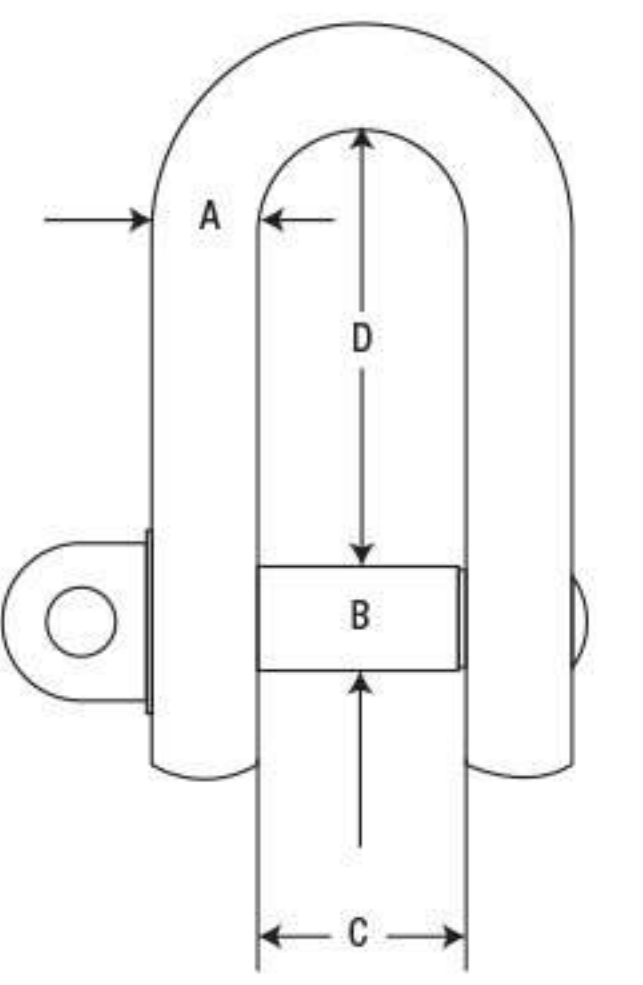

Screw Pin Dee Shackle



FORGED ALLOY STEEL AND HOT DIP GALVANIZED, TOYOLIFT RED COLOR SCREW PIN SHACKLES, TESTED AND CERTIFIED							
Size	S.W.L	A	B	C	D		Weight
					BOW	DEE	
Inch	Tons	mm	Pin Dia.	mm	mm	mm	Kgs/each
3/8"	1.00	9.5	11	17	36.5	32	0.15
7/16"	1.50	11	12	18	42.5	36.5	0.21
1/2"	2.00	12.7	16	20.6	47.3	41.3	0.37
5/8"	3.25	16	19.8	27	60.5	51	0.65
3/4"	4.75	19	22	32	71.5	62	1.04
7/8"	6.50	21.7	27	36.6	84	74.8	1.56
1"	8.50	25.4	30	43	96	81	2.32
1 1/8"	9.50	28.5	33	46	108	90	3.28
1 1/4"	12.00	31.5	36	51.6	119	100.8	4.51
1 3/8"	13.50	34.9	39	57	133.5	112.5	5.93
1 1/2"	17.00	38	42	60	147	125	7.89
1 3/4"	25.00	44	52	73	178	146.5	13.4
2"	35.00	50	56	82	197	171	18.85
2 1/2"	55	63.5	68	105	267.5	203	37.86

Standard: In accordance with EN 13889

These items meet the performance requirements of US FED Specification

FORGED ALLOY STEEL AND HOT DIP GALVANIZED, TOYOLIFT RED COLOR SAFETY PIN SHACKLES, TESTED AND CERTIFIED

Size	S.W.L	A	B	C	D	Weight
Inch	Tons	mm	mm	mm	mm	
3/8"	1.00	9.5	12	17	36.5	0.17
7/16"	1.50	11	12	18	42.5	0.25
1/2"	2.00	12.7	16	20.6	47.3	0.44
5/8"	3.25	16	19.8	27	60.5	0.79
3/4"	4.75	19	22	32	71.5	1.26
7/8"	6.50	22	27	36.6	84	1.88
1"	8.50	25	30	43	96	2.78
1 1/8"	9.50	28.5	33	46	108	3.87
1 1/4"	12.00	31.8	36	51.6	119	5.26
1 3/8"	13.50	34.9	39	57	133.5	6.94
1 1/2"	17.00	38	42	60	147	8.79
1 3/4"	25.00	44	52	73	178	14.99
2"	35.00	50	56	82	197	20.65
2 1/2"	55.00	63.5	68	105	267	41.05
3"	85.00	75	85	127	320	62.00
3 1/2"	120	89	95	146	381	110
4"	150	102	108	165	400	160
4 3/4"	200	120	130	175	500	235

Standard: In accordance with EN 13889

These items meet the performance requirements of US FED Specification

TURN BUCKLES Tendeurs

TURN BUCKLES - TL - 226 EYE & EYE



TURN BUCKLES - TL - 227 JAW & EYE



TURN BUCKLES - TL - 228 JAW & JAW



Range - 1/4 X 4 " to 2-3/4" x 24"

All dimensions are subject to change without prior notice

Standard: In accordance with EN 13889

SAFETY PIN BOW SHACKLES

TL-2130

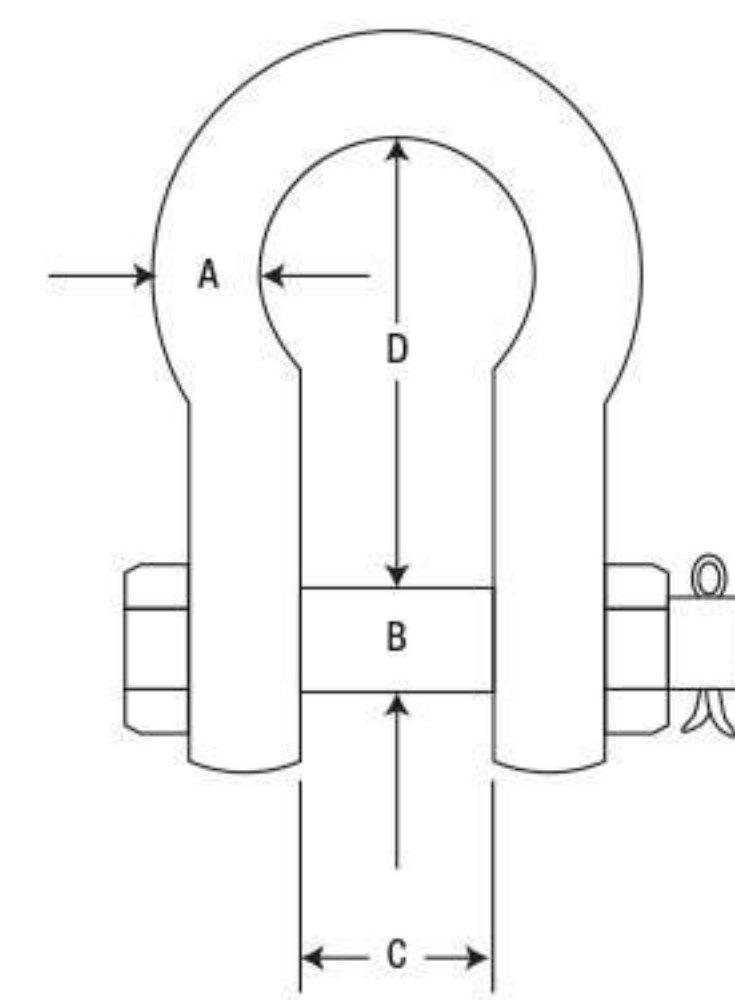

Safety Pin Bow Shackle

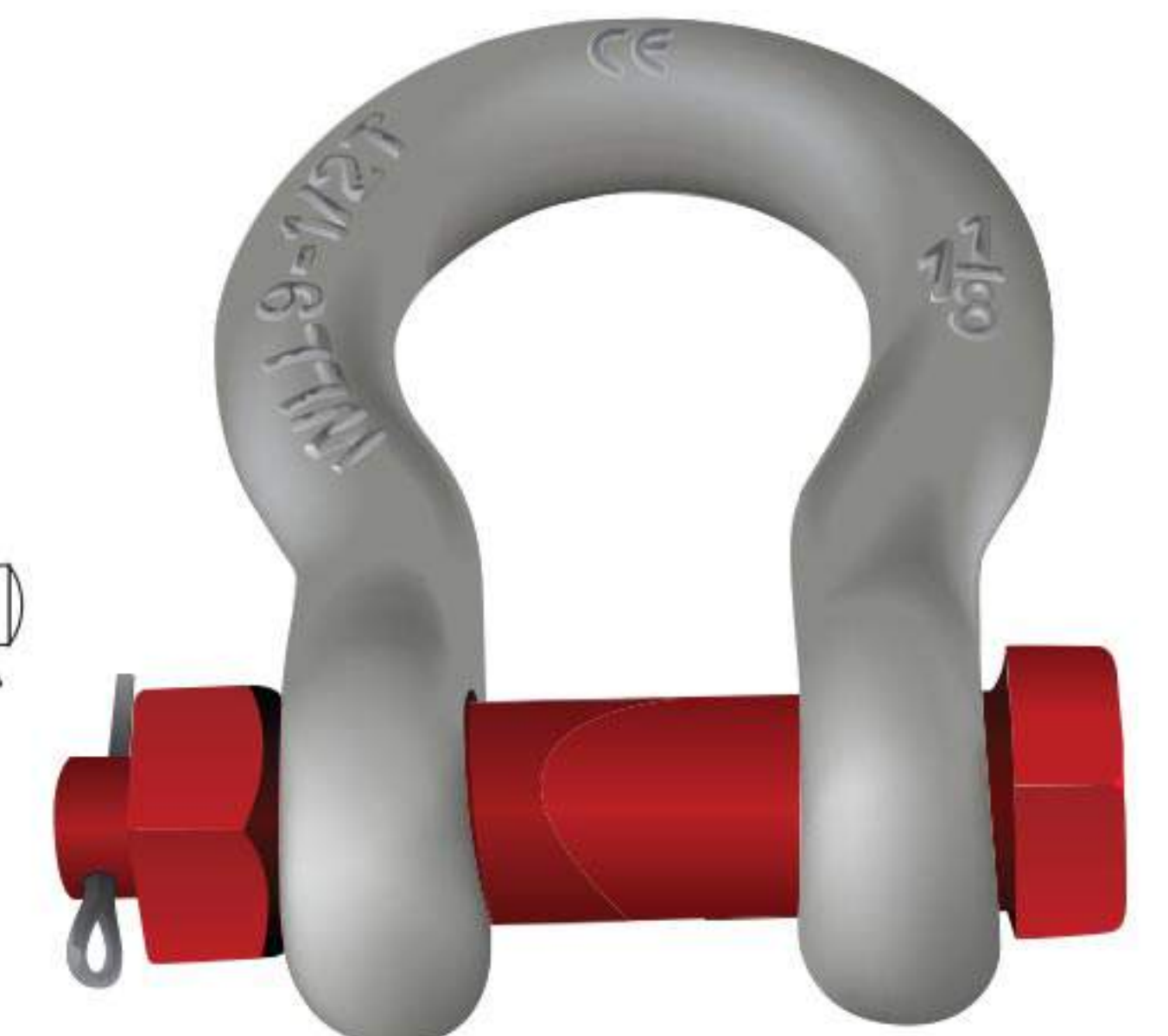

ELECTRIC PALLET TRUCK Transpalette électrique



TL-CBD15W

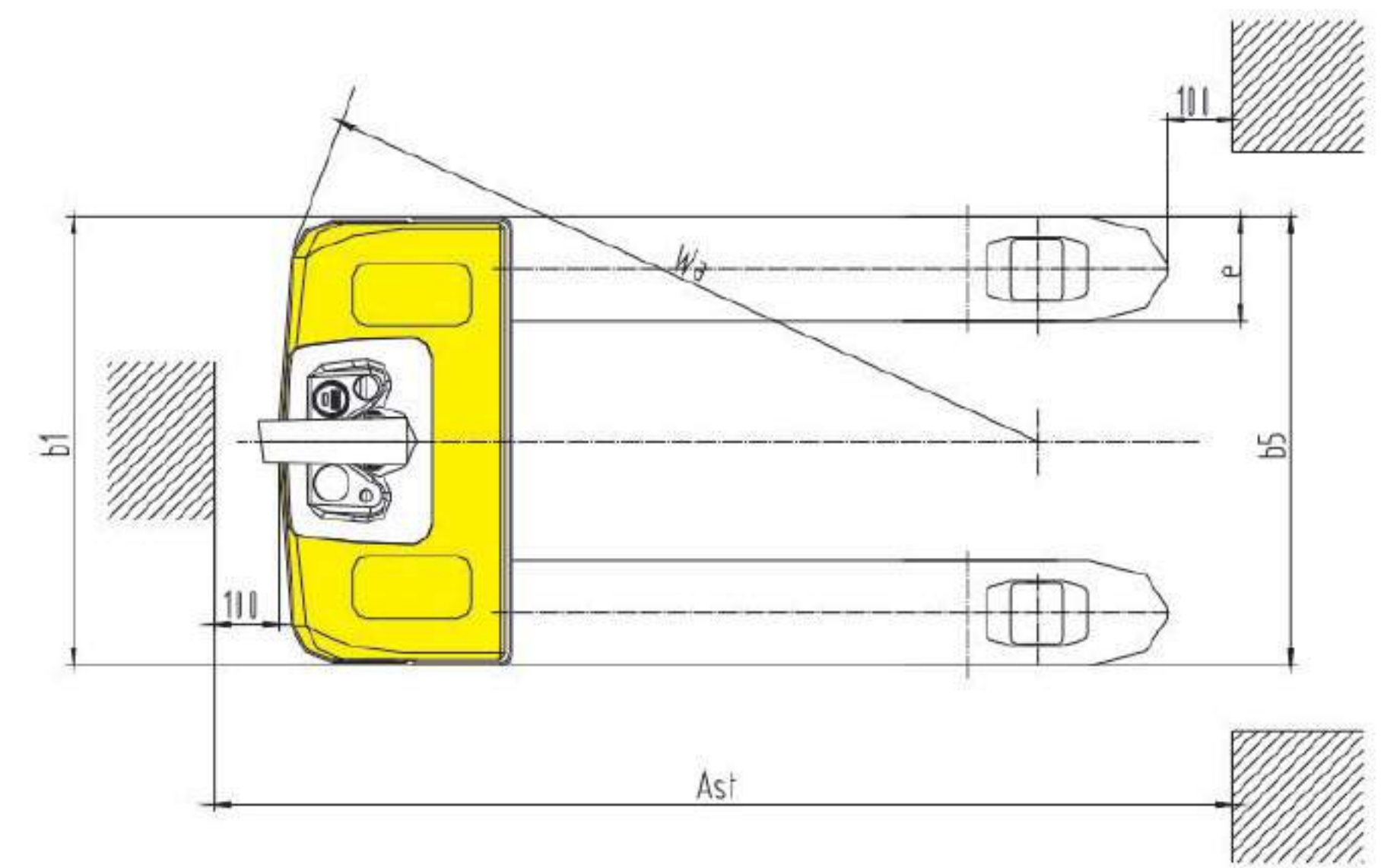
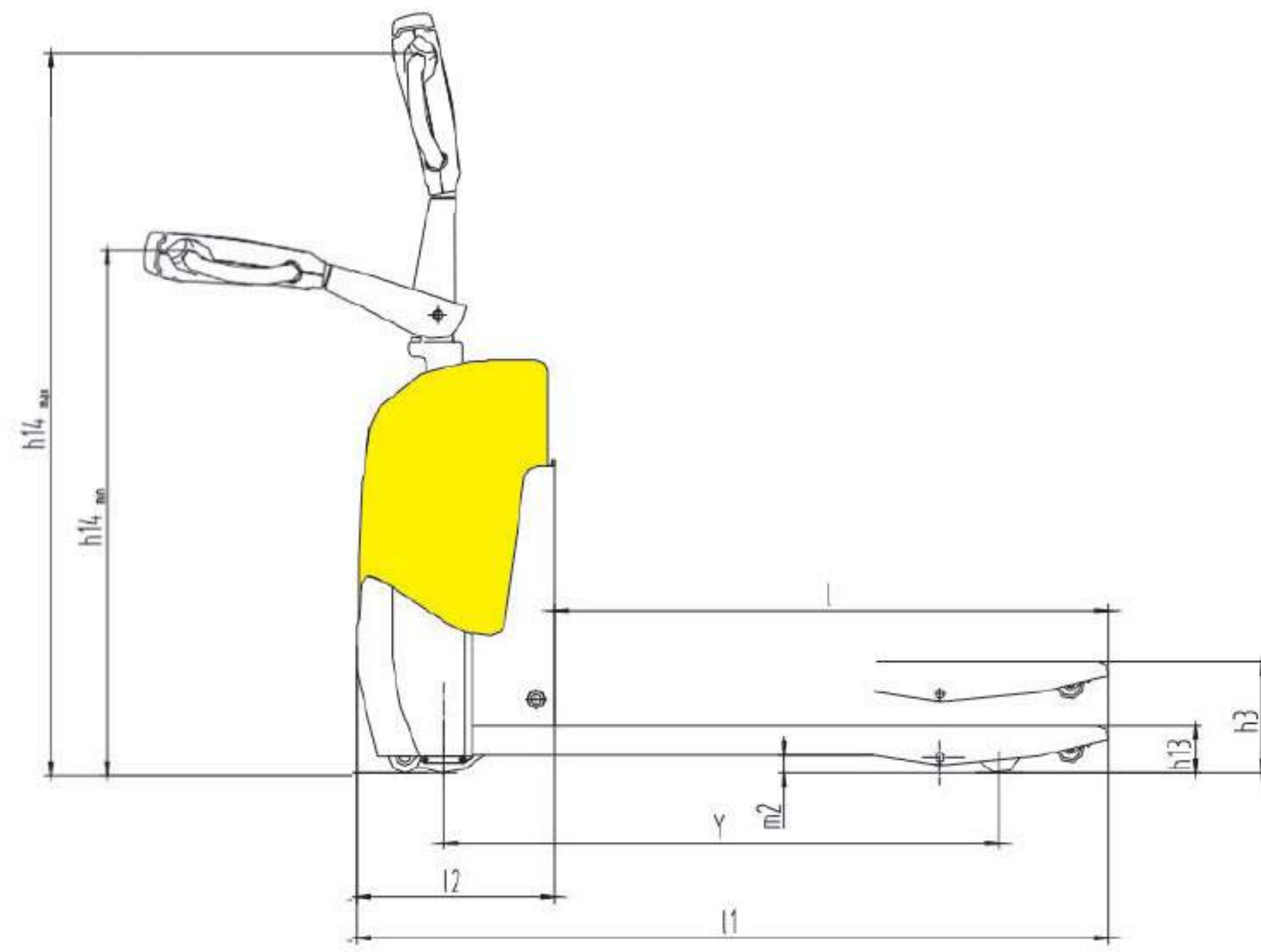

TL -CBD20R-II

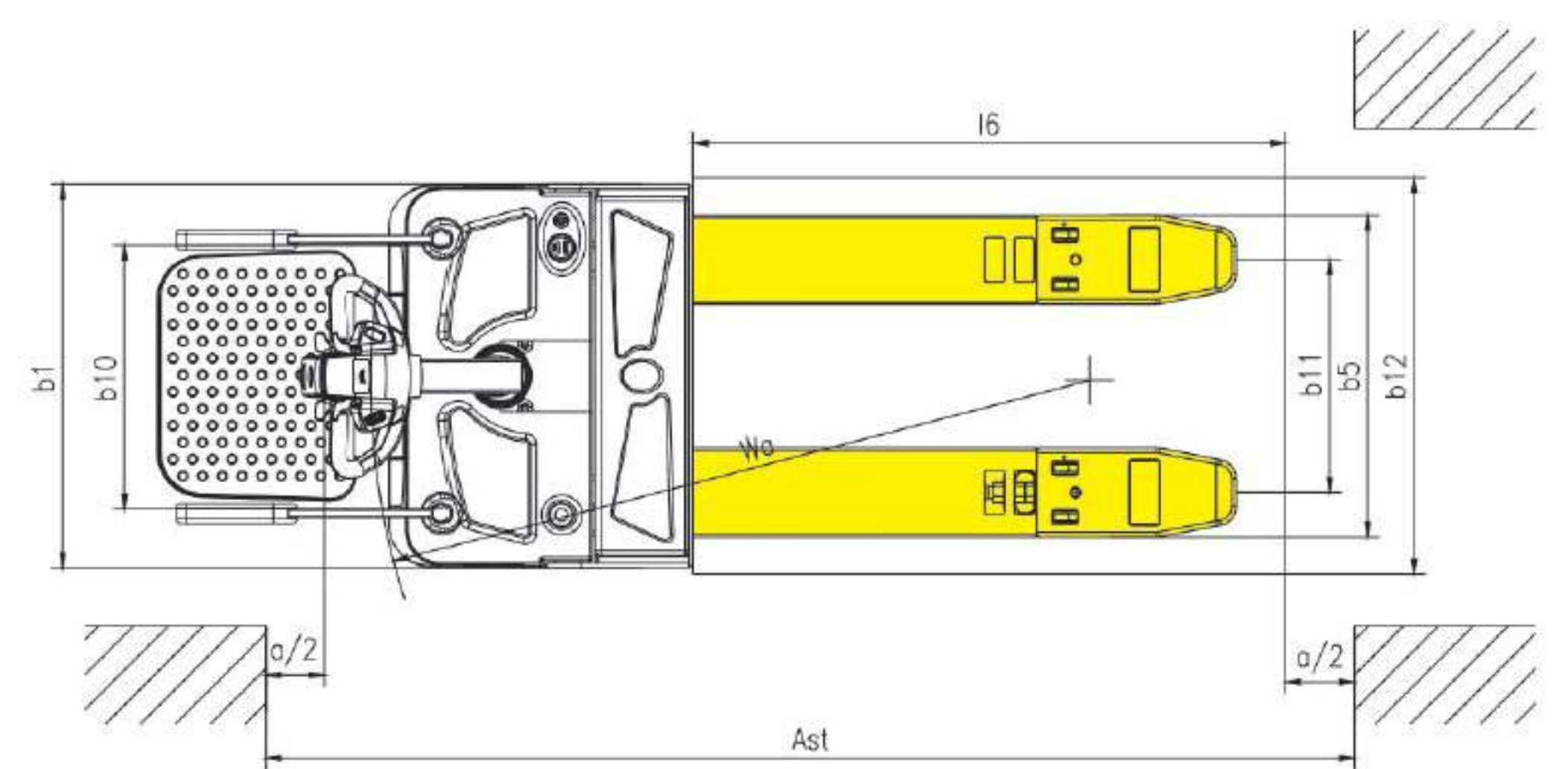
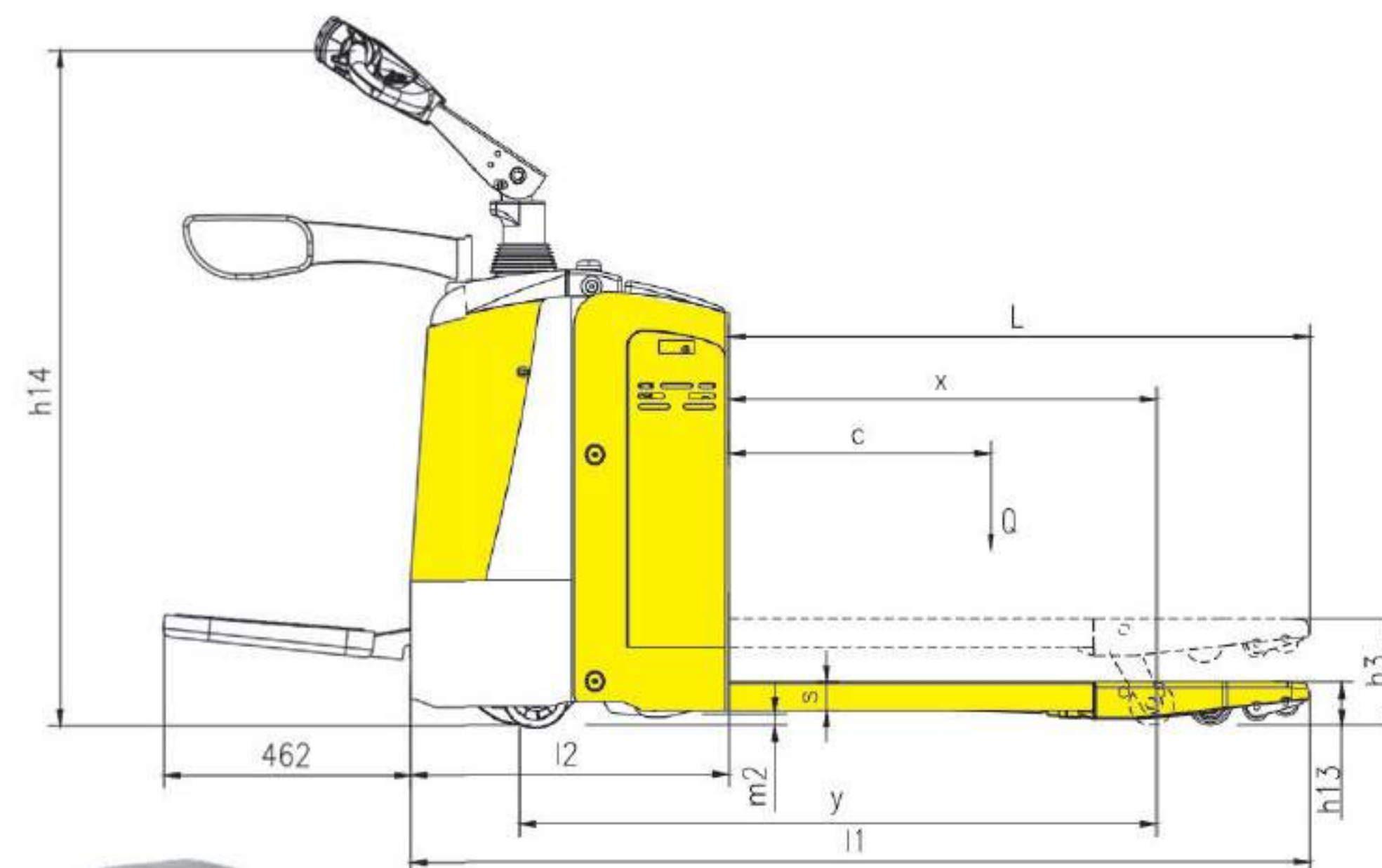

Model	Unit	TL-CBD15W	TL -CBD20R-II
Load capacity	Q (kg)	1500	2000
Fork height lowered	h_{13} (mm)	85/74	82
Tyre size front	(mm)	Ø195	Ø250x70
Tyre size rear	(mm)	Ø80/Ø74	Ø82/Ø126(98)
Additional wheel dimensions	(mm)	-	Ø127/57
Max. lift height	h_3 (mm)	190/180	202
Height of tiller in drive position min/max	h_{14} (mm)	950/1310	1150/1430
Overall length	l_1	1525/1595	1710/1760/1830
Length to face of forks	l_2 (mm)	373	610
Fork dimensions	s/e/l(mm)	53/160/1150(1220)	53/180/1100(1150/1220)
Width overall forks	b_5 (mm)	520/1550/685	520/550/650/685
Aisle width for pallets 1000x1200 crossways	A_{st} (mm)	1725/1795	1910/1960/2030
Aisle width for pallets 1000x1200 lengthways	A_{st} (mm)	1775/1795	2010/2010/2030
Turning radius	W_a (mm)	1347/1415	1550/1600/1670
Travel speed laden/unladen	km/h	5.3/5.8	7/7.1
Battery Voltage, Nominal capacity K5	V/Ah	24/80	24/210
Battery weight	Kg	49	196
Service weight	Kg	230	710

All dimensions are subject to change without prior notice

ALLOY STEEL CHAIN chaîne Alliage de levage

CALIBRATED LOAD CHAIN

Used for - Chain Hoist and Lever Hoist

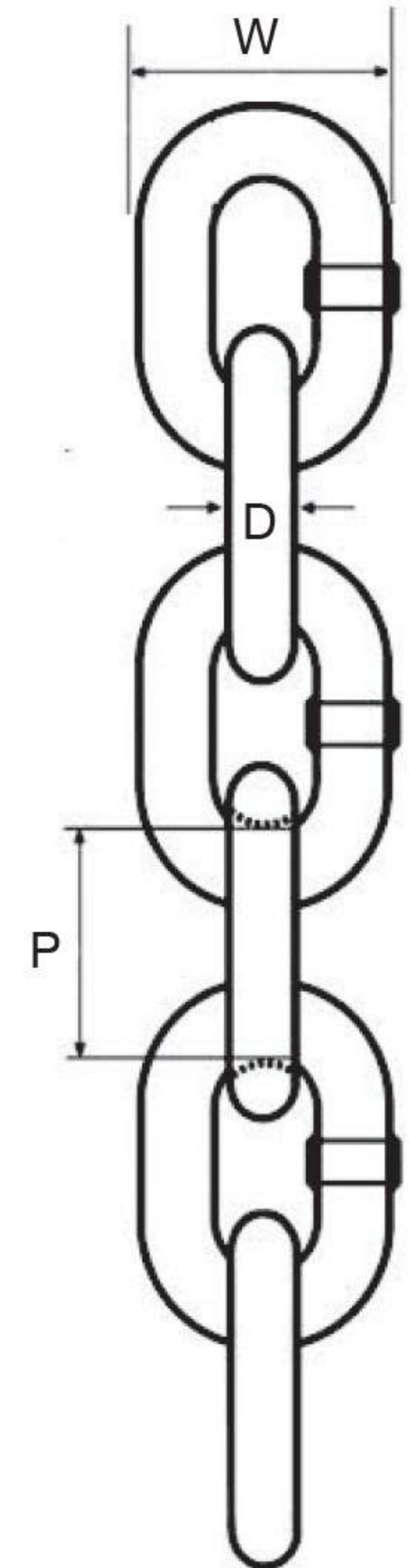
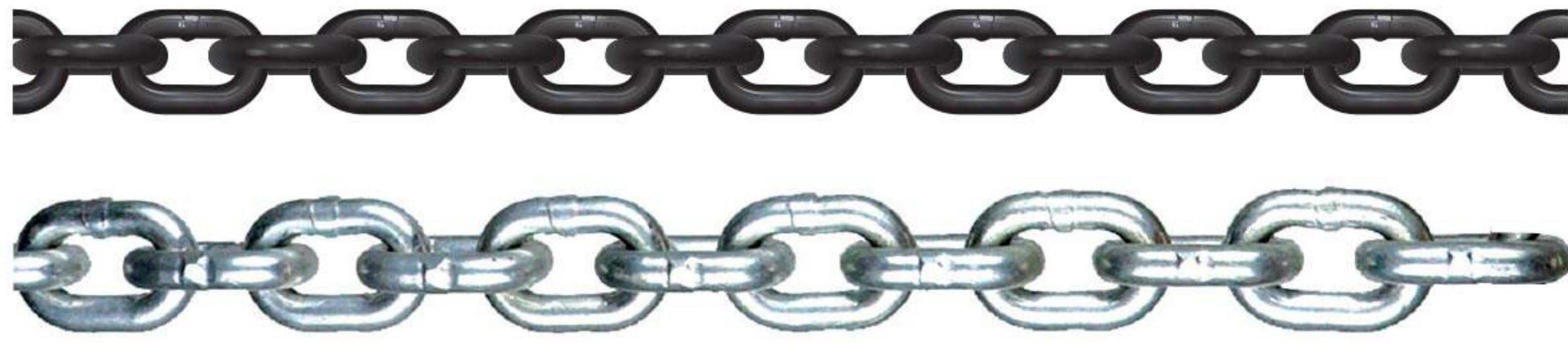

Item No.	Material Diameter D(mm)	Pitch P(mm)	Outside Width W(mm)	Working Load limit (KN)	Min. Breaking Load (KN)	Weight kg/m
0515	5	15	17	7.84	31.38	0.55
0618	6	18	20	11.76	47.07	0.78
0631	6.3	19	22.6	12.5	49.9	0.86
0711	7.1	21	23	15.69	62.76	1.09
1824	8	24	26	19.61	78.45	1.4
0927	9	27	32.2	25	102	1.76
1030	10	30	33	31.38	125.52	2.22
0112	11.2	34	39	38	154	2.8

Standard: EN 818-7

T (8) ALLOY STEEL LIFTING CHAIN

- Heat treated for tensile strength, resistance to wear and shock absorbing capabilities.
- Recognizable by the T8 embossed mark.

PLAIN TROLLEY Chariot porte palan

Push Trolley [Model : TPT]							
Model	Capacity	I-Beam Width (mm)	N.W. (kg)	A (mm)	B (mm)	C (mm)	H (mm)
TPT - 005	0.5 t	50-220	5	285	198	158	64.5
TPT - 010	1t	58-220	8.7	300	238	183	66
TPT - 020	2t	66-220	13.9	300	277	208	75
TPT - 030	3t	74-220	23.5	328	324	249	85
TPT - 050	5t	90-220	40	354	373	296.5	100

Standard: EN 13157

All dimensions are subject to change without prior notice

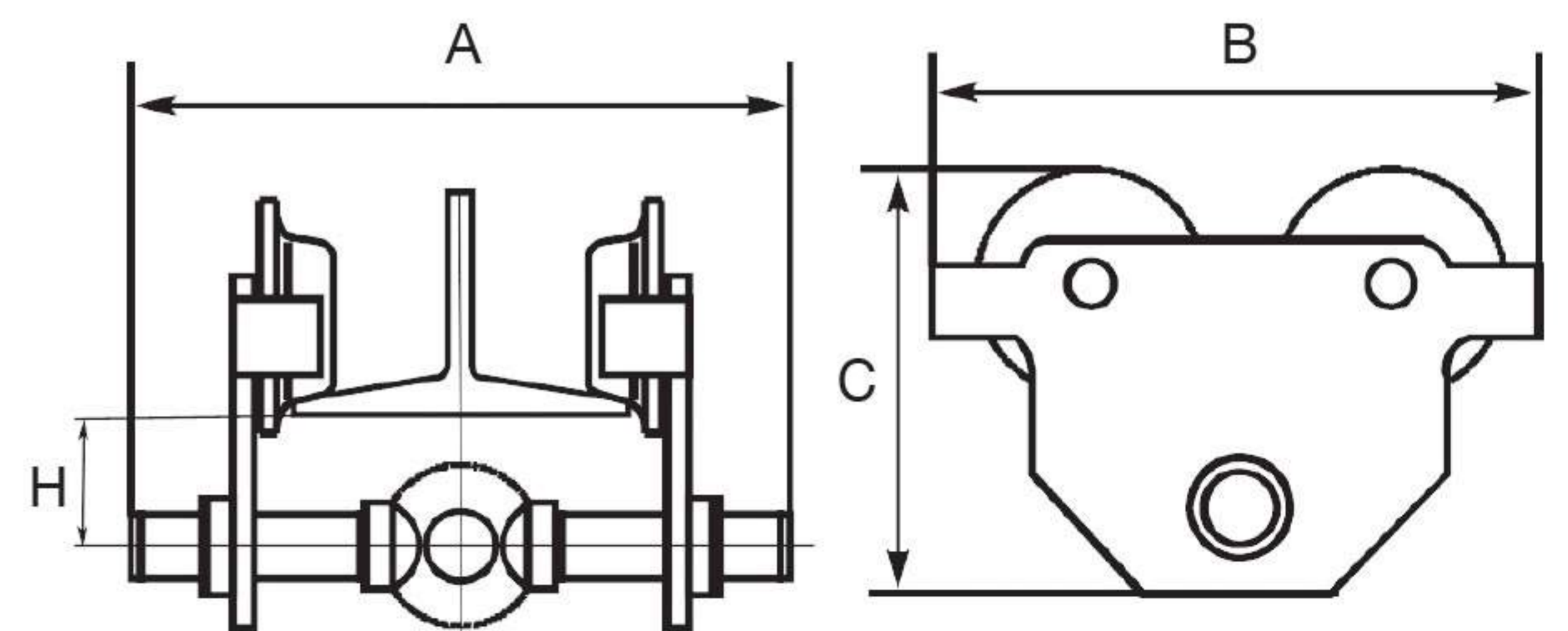

MANUAL GEAR TROLLEY Chariot porte palan à chaîne

Gear Trolley [Model : TGT]							
Model	Capacity	I-Beam Width (mm)	N.W. (kg)	A (mm)	B (mm)	C (mm)	H (mm)
TGT - 005	0.5 t	50-220	9	352.5	198	158	64.5
TGT - 010	1t	58-220	12.6	353.5	238	183	66
TGT - 020	2t	66-220	18.5	362	277	208	75
TGT - 030	3t	74-220	28	406.5	324	249	85
TGT - 050	5t	90-220	45	434.5	373	296.5	100
TGT - 100	10t	125-203	103	487.5	455	490	275.5

Standard: EN 13157

All dimensions are subject to change without prior notice

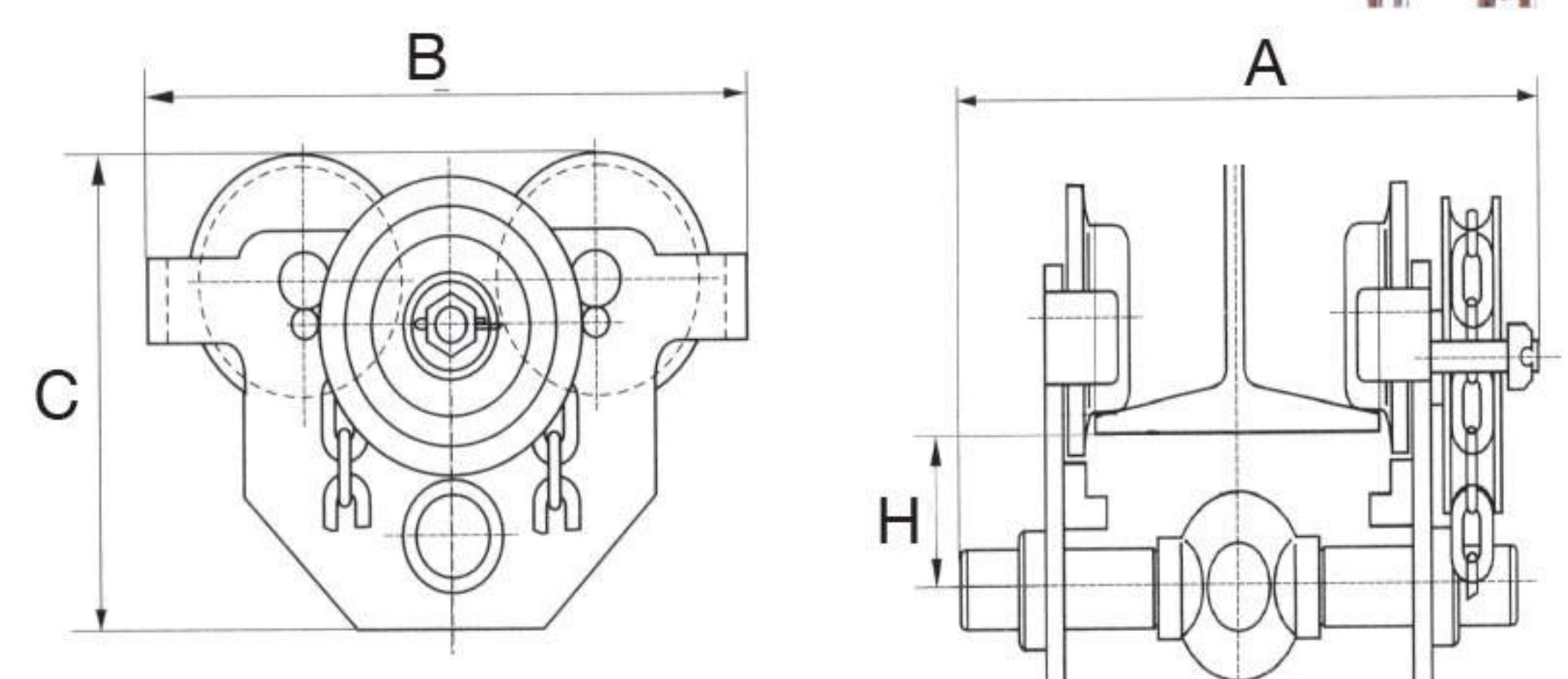
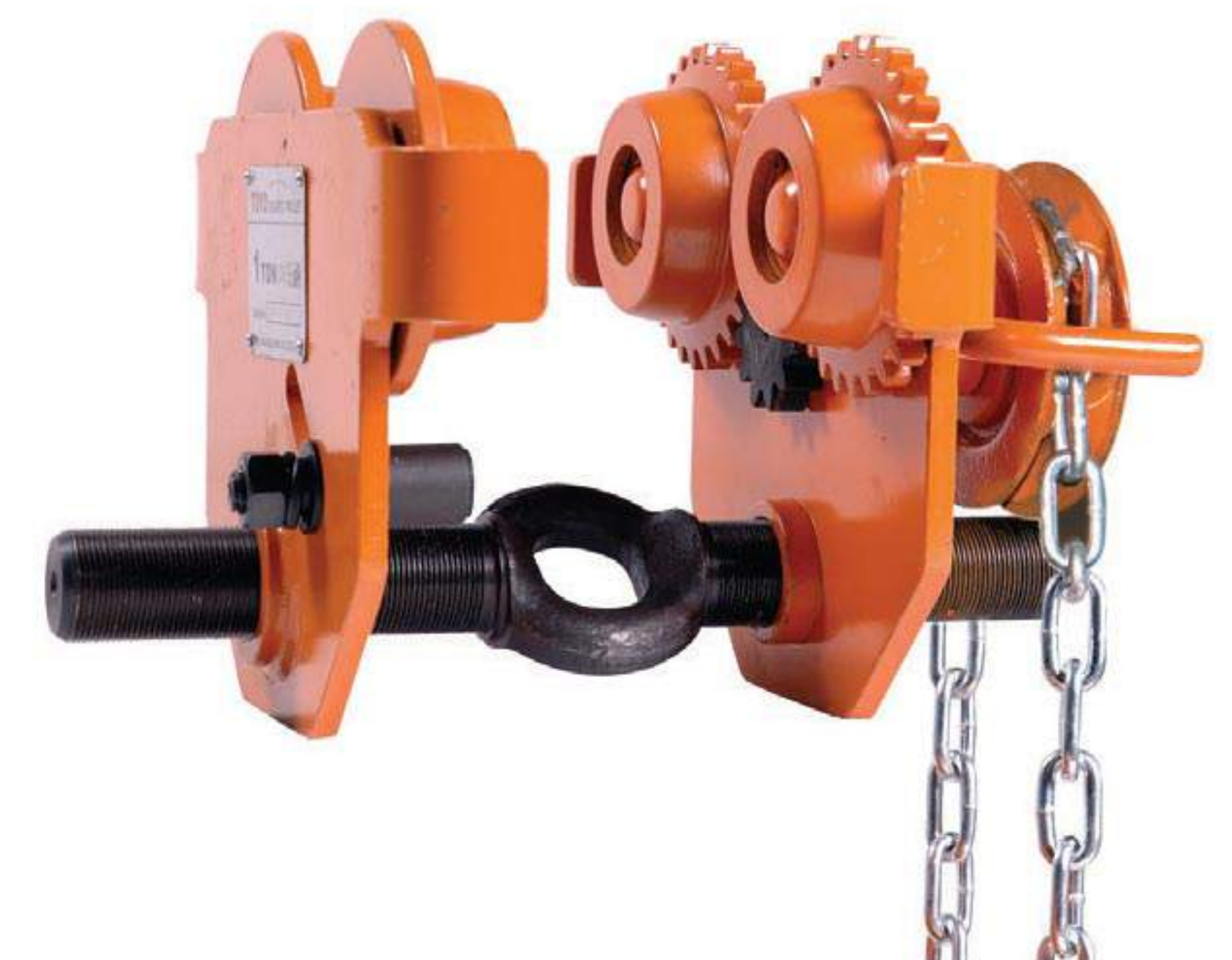

PORTABLE GANTRY ALUMINUM Grue portique en Aluminium

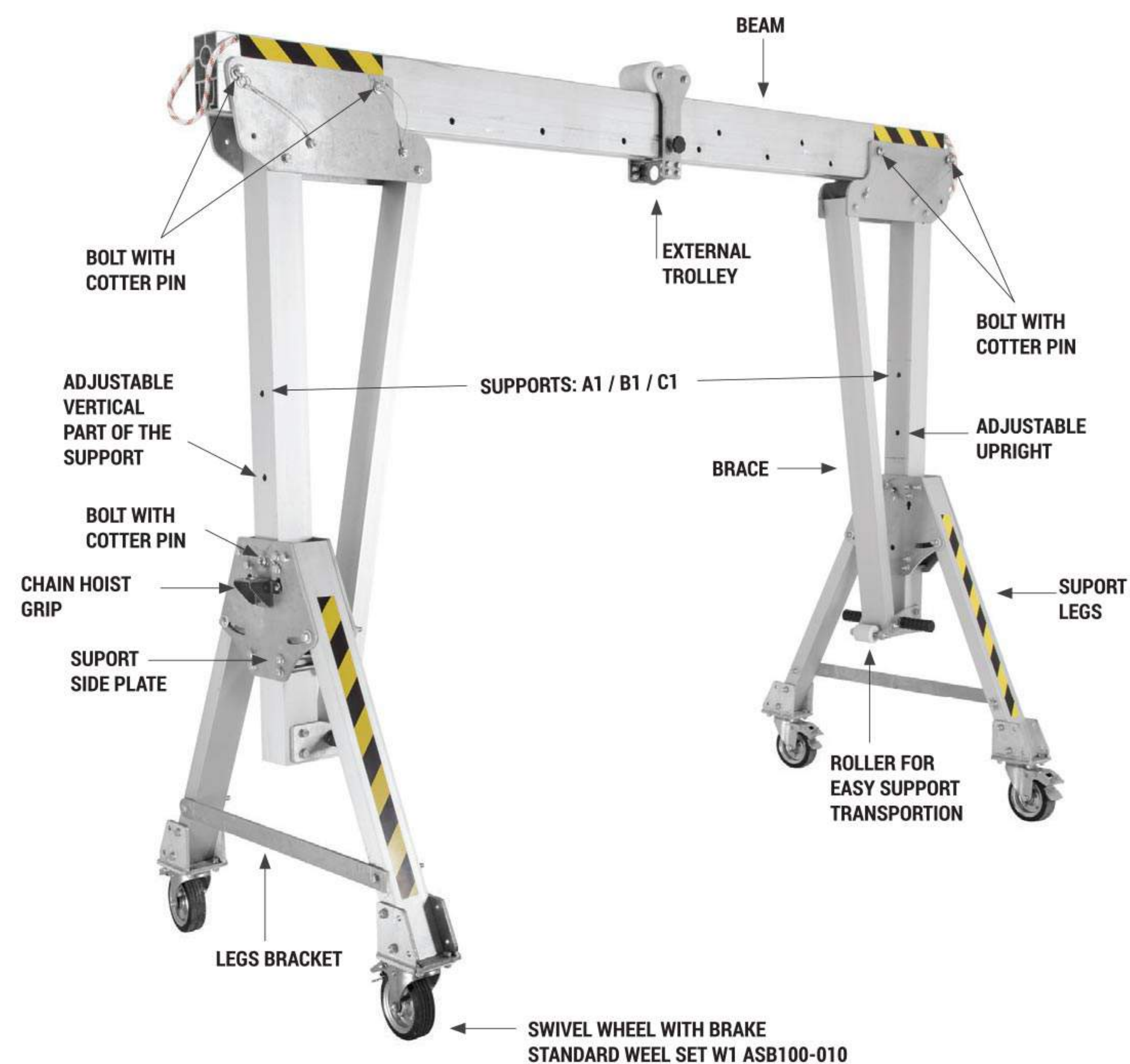

Aluminium gantry crane (ASB series) is a complete, lightweight, fully customizable, portable device designed for lifting loads up to the related Working Load Limit (WLL).

- Beam length: from 2 to 7 meters
- Support height: three basic types - A1 / B1 / C1
- Working Load Limit (WLL): from 1500 kg up to 3500 kg (depends on configuration - please see Technical Data Table).
- Safety factor for lifting loads: 2,1:1.
- Safety factor for personal rescue: 10:1.
- Protection for maximum five people at the same time.
- Standard: EN 795/A: 2012-CEN/TS 16415/A: 2013

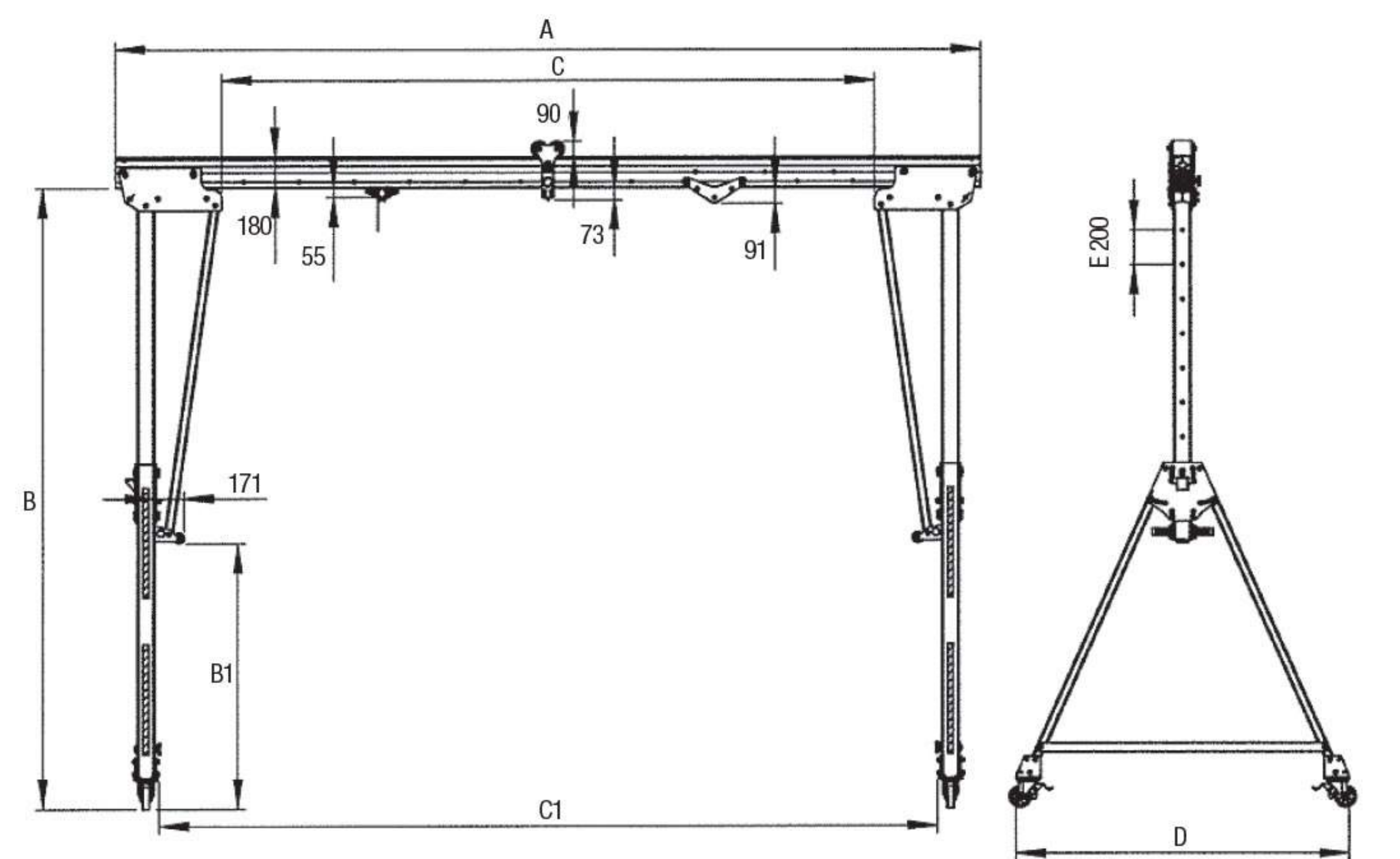

BENEFITS:

- Modular design flexibility
- Fast assembly using bolt with cotter pin. No need additional tools
- RUP50x-T lifting devices can be used for loads lifting operations.
- RUP50x-T rescue lifting devices can be used for rescue purposes.

TECHNICAL DATA TABLE						
"A" Total Beam length (mm)	"C" Working span (mm)	"C1" Bottom span (mm)	Beam weight (kg)	A1 Support (one side 38.2kg) WLL (kg)	B1 Support (one side 50.2kg) WLL (kg)	C1 Support (one side 72kg) WLL (kg)
2000	770	1496	26.7	3500	3000	3000
3000	1770	2496	40.1	3500	3000	3000
4000	2770	3496	53.4	3000	3000	3000
5000	3770	4496	66.5	2500	2500	2500
6000	4770	5496	80.1	2000	2000	2000
7000	5770	6496	93.5	1500	1500	1500
Support weight (one side) (kg)				38.2	50.2	71.8
"B" - Support height (min-max) (mm)				1594...2194	2207...3607	3230...5430
"B1" Under roller height (min-max) (mm)				34...634	141...1541	164...2364
"D" - Legs spacing (mm)				1115	1928	2834
"E" - Support height increment (mm)				200		